



## CARIBBEAN EXAMINATIONS COUNCIL

### Caribbean Advanced Proficiency Examination

# Physics Syllabus

**Effective for examinations from May/June 2008**

Correspondence related to the syllabus should be addressed to:

The Pro-Registrar  
Caribbean Examinations Council  
Caenwood Centre  
37 Arnold Road, Kingston 5, Jamaica, W.I.

Telephone Number: (876) 920-6714  
Facsimile Number: (876) 967-4972  
E-mail address: [cxcwzo@cxc.org](mailto:cxcwzo@cxc.org)  
Website: [www.cxc.org](http://www.cxc.org)

Copyright © 2007 by Caribbean Examinations Council  
The Garrison, St. Michael BB 11158, Barbados



**This document CXC A16/U2/07 replaces CXC A16/U2/01 issued in 2001.**

**Please note that the syllabus was revised and amendments are indicated by italics and vertical lines.**

**First issued 1999  
Revised 2001  
Revised 2007**

**Please check the website, [www.cxc.org](http://www.cxc.org) for updates on CXC's syllabuses.**



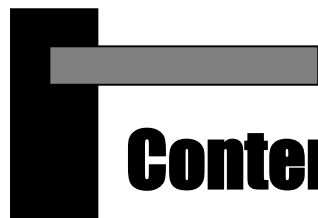

# Contents

RATIONALE .....	1
AIMS .....	1
SKILLS AND ABILITIES TO BE ASSESSED .....	2
PRE-REQUISITES OF THE SYLLABUS .....	5
STRUCTURE OF THE SYLLABUS.....	5
UNIT 1: MECHANICS, WAVES AND PROPERTIES OF MATTER	
MODULE 1: MECHANICS.....	6
MODULE 2: OSCILLATIONS AND WAVES.....	18
MODULE 3: THERMAL AND MECHANICAL PROPERTIES OF MATTER.....	27
UNIT 2: <i>ELECTRICITY AND MAGNETISM, A. C. THEORY AND ELECTRONICS AND</i> ATOMIC AND NUCLEAR PHYSICS	
MODULE 1: <i>ELECTRICITY AND MAGNETISM</i> .....	37
MODULE 2: <i>A. C. THEORY AND ELECTRONICS</i> .....	47
MODULE 3: ATOMIC AND NUCLEAR PHYSICS .....	56
OUTLINE OF ASSESSMENT .....	64
REGULATIONS FOR PRIVATE CANDIDATES .....	68
REGULATIONS FOR RESIT CANDIDATES.....	69
ASSESSMENT GRID .....	69
RESOURCES.....	70
GLOSSARY .....	71
LIST OF MINIMUM LABORATORY REQUIREMENTS .....	76
LIST OF PHYSICAL CONSTANTS .....	78
MATHEMATICAL REQUIREMENTS.....	80
SUMMARY OF KEY QUANTITIES, SYMBOLS AND UNITS .....	83





# Introduction

The Caribbean Advanced Proficiency Examination (CAPE) is designed to provide certification of the academic, vocational and technical achievement of students in the Caribbean who, having completed a minimum of five years of secondary education, wish to further their studies. The examination addresses the skills and knowledge acquired by students under a flexible and articulated system where subjects are organised in 1-Unit or 2-Unit courses with each Unit containing three Modules.

Subjects examined under CAPE may be studied concurrently or singly, or may be combined with subjects examined by other examination boards or institutions.

*The Caribbean Examinations Council offers three types of certification. The first is the award of a certificate showing each CAPE Unit completed. The second is the CAPE diploma, awarded to candidates who have satisfactorily completed at least six Units, including Caribbean Studies. The third is the CAPE Associate Degree, awarded for the satisfactory completion of a prescribed cluster of seven CAPE Units including Caribbean Studies and Communication Studies. For the CAPE diploma and the CAPE Associate Degree, candidates must complete the cluster of required Units within a maximum period of five years.*



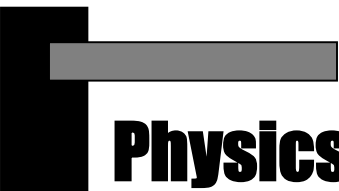

# Physics Syllabus

## ◆ RATIONALE

Science plays a major role in the evolution of knowledge. It empowers us to use creative and independent approaches to problem solving. It arouses our natural curiosity and enables us to meet diverse and ever expanding challenges. It enhances our ability to inquire, seek answers, research and interpret data. These skills lead to the construction of theories and laws that help us to explain natural phenomena and exercise control over our environment. Science is, thus, an integral component of a balanced education.

The most important natural resource in the Caribbean is its people. If the Caribbean is to play an important role in the new global village and survive economically, a sustained development of the scientific and technological resources of its people is essential.

Physics is generally regarded as the most fundamental scientific discipline. The study of Physics is necessary to explain our physical environment. In fact, this is the role of the laws and theories of Physics that influence every aspect of our physical existence. In particular, whatever conveniences and luxuries we enjoy as citizens of Caribbean nations can either directly or indirectly be traced to these fundamental physical laws and theories.

This CAPE syllabus in Physics is, therefore, designed to provide a coherent course of study which addresses, in addition to a specific knowledge base, the development of related skills and attitudes. The syllabus takes into account the requirements for tertiary education at regional and international institutions. It is also structured in such a way as to ensure that students become aware of their moral, social, and ethical responsibilities, as well as the benefits intrinsic to the practical application of scientific knowledge to careers in the scientific field.

## ◆ AIMS

The syllabus aims to enable students to:

1. acquire understanding and knowledge of technological and scientific applications of Physics, especially in the Caribbean context;
2. demonstrate an awareness and understanding of natural phenomena which affect this region and their sensitivity to concerns about the preservation of our environment;
3. develop an understanding of the scientific process and their recognition of its usefulness and its limitations;

4. encourage the development of rational and ethical attitudes and behaviours in the application of Physics;
5. develop critical thinking, analytical and inquiry skills;
6. provide appropriate scientific training for the purposes of employment, further studies and personal enhancement;
7. stimulate an interest in and love for the study of Physics.

## ◆ **SKILLS AND ABILITIES TO BE ASSESSED**

The skills students are expected to develop on completion of this syllabus have been grouped under three main headings:

- (i) Knowledge and Comprehension;
- (ii) Use of Knowledge; and
- (iii) Experimental Skills.

### **Knowledge and Comprehension (KC)**

Knowledge	The ability to identify, remember, and grasp the meaning of basic facts, concepts and principles.
Comprehension	The ability to select appropriate ideas, match, compare and cite examples of facts, concepts and principles in familiar situations.

### **Use of Knowledge (UK)**

Application	The ability to: <ul style="list-style-type: none"> <li>- use facts and apply concepts, principles and procedures in familiar and novel situations;</li> <li>- transform data accurately and appropriately;</li> <li>- use formulae accurately for computational purposes.</li> </ul>
Analysis and Interpretation	The ability to: <ul style="list-style-type: none"> <li>- identify and recognise the component parts of a whole and interpret the relationship among those parts;</li> </ul>

- identify causal factors and show how they interact with each other;
- infer, predict and draw conclusions;
- make necessary and accurate calculations and recognise the limitations and assumptions of data.

Synthesis

The ability to:

- combine component parts to form a new and meaningful whole;
- make predictions and solve problems.

Evaluation

The ability to:

- make reasoned judgements and recommendations based on the value of ideas, information and their implications;
- analyse and evaluate information from a range of sources to give concise and coherent explanations of scientific phenomena;
- assess the validity of scientific statements, experiments, results, conclusions and inferences.

### **Experimental Skills – (XS)**

Observation, Recording and Reporting

The ability to:

- select observations relevant to the particular activity;
- make accurate observations and minimise experimental errors;
- report and recheck unexpected results;
- select and use appropriate models of recording data or observations, for example, graphs, tables, diagrams;

### **Experimental Skills – (XS)** **(cont'd)**

- record observations, measurements, methods and techniques with due regard for precision, accuracy, and units;
- present data in an appropriate manner, using the

accepted convention of recording errors and uncertainties;

- organise and present information, ideas, descriptions and arguments clearly and logically in a complete report, using spelling, punctuation and grammar with an acceptable degree of accuracy;
- report accurately and concisely using scientific terminology and conventions as necessary.

Manipulation and Measurement The ability to:

- follow a detailed set or sequence of instructions;
- use techniques, apparatus and materials safely and effectively;
- make observations and measurements with due regard for precision and accuracy.

Planning and Designing The ability to:

- make predictions, develop hypotheses and devise means of carrying out investigations to test them;
- plan experimental procedures and operations in a logical sequence within time allocated;
- use experimental controls where appropriate;
- modify an original plan or sequence of operations as a result of difficulties encountered in carrying out experiments or obtaining unexpected results;
- take into account possible sources of errors and danger in the design of an experiment;
- select and use appropriate equipment and techniques.



## ◆ PRE-REQUISITES OF THE SYLLABUS

Any person with a good grasp of the Caribbean Secondary Education Certificate (CSEC) Physics syllabus, or its equivalent, should be able to pursue the course of study defined by this syllabus. However, successful participation in the course of study will also depend on the possession of good verbal and written communication *and mathematical skills* (see page 78 for mathematical requirements).

## ◆ STRUCTURE OF THE SYLLABUS

*This syllabus is arranged into TWO Units, each made up of three Modules. Whilst each Module in each Unit is independent, together they form a coherent course of study which should prepare candidates for the world of work and studies at the tertiary level.*

### **Unit 1: Mechanics, Waves, Properties of Matter**

*Unit 1 is expected to be covered in approximately 150 hours, and consists of three Modules. This Unit is structured as follows:*

Module 1	-	Mechanics
Module 2	-	Oscillations and Waves
Module 3	-	Thermal and Mechanical Properties of Matter

### **Unit 2: Electricity and Magnetism, A. C. Theory and Electronics and Atomic and Nuclear Physics**

*Unit 2 is expected to be covered in approximately 150 hours, and consists of three Modules. This Unit is structured as follows:*

Module 1	-	Electricity and Magnetism
Module 2	-	A. C. Theory and Electronics
Module 3	-	Atomic and Nuclear Physics

*The syllabus is arranged into two (2) Units, Unit 1 which will lay the foundation, and Unit 2 which expands on and applies the concepts formulated in Unit 1. It is, therefore, recommended that Unit 2 be taken after satisfactory completion of Unit 1 or a similar course. Each Unit will be certified separately.*

*For each Module there are general and specific objectives. The general and specific objectives indicate the scope of the content, including practical work, on which the examination will be based. However, unfamiliar situations may be presented as stimulus material in a question.*

*Explanatory notes are provided to the right of some specific objectives. These notes provide further guidance to teachers as to the level of detail required.*

*The single underlining of a specific objective and its explanatory notes, indicate those areas of the syllabus that are suitable for practical work. However, practical work should not necessarily be limited to these objectives.*

*It is recommended that of the approximately 50 hours suggested for each Module, a minimum of about 20 hours be spent on laboratory-related activities, such as conducting experiments, making field trips and viewing audio-visual materials.*

# ◆ UNIT 1: MECHANICS, WAVES, PROPERTIES OF MATTER

## MODULE 1: MECHANICS

### GENERAL OBJECTIVES

On completion of this Module, students should:

1. understand physical quantities;
2. apply the SI system of units and standard conventions;
3. solve problems of bodies at rest, in uniform motion, or uniformly accelerated motion under the influence of forces in one and two dimensions;
4. appreciate the effects of forces acting on a body;
5. understand the principle of conservation of energy;
6. design and carry out experiments to test relationships between physical quantities;
- || 7. *appreciate that the measurement of a physical quantity is subject to uncertainty.*

### SPECIFIC OBJECTIVES

### EXPLANATORY NOTES

#### 1. Physical Quantities

Students should be able to:

1.1	<i>express physical quantities as a numerical magnitude and unit;</i>	<i>Some quantities are dimensionless, for example, refractive index, relative density.</i>	
1.2	distinguish between scalar and vector quantities, and state examples;		
1.3	<u>combine and resolve vectors;</u>	<u>Both graphically and by calculation. Add and subtract vectors using components.</u>	
1.4	<u>measure physical quantities using appropriate instruments;</u>		
1.5	<u>construct and use calibration curves;</u>	<u>Non-linear curves may be included.</u>	

**UNIT 1**  
**MODULE 1: MECHANICS (cont'd)**

**SPECIFIC OBJECTIVES**

**Physical Quantities (cont'd)**

Students should be able to:

- 1.6 *rearrange relationships between physical quantities so that linear graphs may be plotted;*
- 1.7 *distinguish between precision and accuracy;*
- 1.8 *estimate the uncertainty in a derived quantity from actual, fractional or percentage uncertainties.*

**2. SI Units**

Students should be able to:

- 2.1 *state the base quantities including their symbols and S.I. units;*
- 2.2 *use base quantities or units to obtain expressions for derived quantities or units;*
- 2.3 *use the Avogadro constant (the number of atoms in 0.012 kg of the C-12 isotope) as a numerical entity;*
- 2.4 *use the concept of the mole as the quantity of substance containing a number of particles equal to the Avogadro constant;*
- 2.5 *use prefixes and their symbols to express multiples (up to  $10^9$ ) and sub-multiples (down to  $10^{-12}$ ) of units of base and derived quantities;*
- 2.6 *use base units to check the homogeneity of physical equations.*

**EXPLANATORY NOTES**

*Include logarithmic plots to test exponential and power law variations.*

*See suggested practical activity on page 15.*

*Mass, length, time, temperature, current, luminous intensity and amount of substance.*

*Summary of key quantities, symbols and units on pages 83 – 86.*

*Solve problems where the indices have to be substituted before calculation.*

*For example,  $C = 6\text{km}/20\mu\text{s}$*



**UNIT 1**  
**MODULE 1: MECHANICS (cont'd)**

**SPECIFIC OBJECTIVES**

**EXPLANATORY NOTES**

**3. Motion**

Students should be able to:

3.1 *explain* displacement, speed, velocity, and acceleration;

3.2 use graphs to represent displacement, speed, velocity, and acceleration in a single dimension;

3.3 *use the gradient of and area under motion graphs to solve problems;*

3.4 derive equations representing uniformly accelerated motion in a single dimension;

*A non-calculus approach may be used.*

$$v = u + at$$

$$v^2 = u^2 + 2as$$

$$s = \frac{(u + v)}{2} t$$

$$s = ut + \frac{1}{2} at^2$$

$$s = vt - \frac{1}{2} at^2$$

3.5 *use the equations of motion to solve problems, on uniformly accelerated motion;*

3.6 *solve problems involving bodies undergoing projectile motion;*

Requires only a non-calculus approach.

3.7 show that projectile motion is parabolic;

*Include horizontal projection.*

3.8 state Newton's laws of motion;

*An UNBALANCED external force is required to change the velocity.*

3.9 *explain* 'linear momentum';

3.10 state the principle of conservation of linear momentum;

**UNIT 1**  
**MODULE 1: MECHANICS (cont'd)**

**SPECIFIC OBJECTIVES**

**EXPLANATORY NOTES**

**Motion (cont'd)**

Students should be able to:

3.11 apply the principle of conservation of linear momentum;

For example, collisions in one or two dimensions, such as in billiards, “explosions” as in the recoil of a gun.

3.12 distinguish between inelastic and perfectly elastic collisions;

Collisions should be limited to two objects only.

3.13 *explain* and use the concept of the impulse of a force;

3.14 draw and interpret ***F-t*** graphs;

*For example, car crash.*

3.15 solve problems related to Newton's laws of motion;

Problems should include uniform acceleration only.

3.16 express angular displacement in radians;

3.17 apply the concept of angular velocity to problems involving circular motion;

3.18 apply the expression  $v = r\omega$  to problems involving circular motion;

3.19 *use equations for centripetal acceleration and centripetal force;*

$$a = r\omega^2 \quad a = \frac{v^2}{r}$$

$$F = mr\omega^2 \quad F = \frac{mv^2}{r}$$

3.20 *use the equations circular motion to solve problems;*

*Include horizontal circles, vertical circles and conical pendulum and banking.*

3.21 use Newton's law of universal gravitation in problems involving attraction between masses;

**UNIT 1**

## MODULE 1: MECHANICS (cont'd)

### SPECIFIC OBJECTIVES

### EXPLANATORY NOTES

#### Motion (cont'd)

Students should be able to:

3.22 *explain and use the term gravitational field strengths (at the Earth's surface or above);*

$$g = \frac{F}{m} \text{ units for } g: \text{Nkg}^{-1}$$

3.23 solve problems involving circular orbits;

*Include apparent weightlessness.*

3.24 *discuss the motion of geostationary satellites and their applications.*

*Compare with other orbits, for example, those of Global Positioning System (GPS) satellites.*

#### **4. Effects of Forces**

Students should be able to:

4.1 explain the origin of the upthrust acting on a body wholly or partially immersed in a fluid, and use this knowledge to solve problems;

*Upthrust due to pressure difference. See suggested practical activity on pages 13 and 14.*

4.2 explain the nature, cause and effects of resistive forces;

Include drag forces in fluids and frictional forces.

4.3 use the concept of terminal velocity to solve problems involving motion through a fluid;

4.4 apply the principle of moments to solve problems;

4.5 use the concepts of static and dynamic equilibria to solve problems.

*Sum of forces equals zero.  
Sum of torques equals zero.*

#### **5. Conservation of Energy**

Students should be able to:

5.1 use the concept of work as the product of force and displacement in the direction of the force;

$$W = Fx$$



**UNIT 1**  
**MODULE 1: MECHANICS (cont'd)**

**SPECIFIC OBJECTIVES**

**EXPLANATORY NOTES**

**Conservation of Energy (cont'd)**

Students should be able to:

5.2 *derive and use the formula for kinetic energy  $E_k = \frac{1}{2} mv^2$ ;*

*A non-calculus approach may be used.*

5.3 distinguish between kinetic and potential energy;

5.4 *distinguish between different types of potential energy;*

*Such as gravitational, electrical, elastic and strain energy.*

5.5 derive and use the formula  $\Delta E_p = mg \Delta h$  for potential energy changes near the Earth's surface;

5.6 apply the concept of power as the rate of doing work;

$P = \frac{W}{t}$ . Also  $P = F \times v$ .

5.7 *apply the concept of efficiency to problems involving energy transfer;*

5.8 state examples of different forms of energy;

Classify forms as mechanical, thermal, chemical, electrical or nuclear.

5.9 describe examples of energy conversion;

Include examples occurring in industry and in every-day life.

5.10 apply the concept of energy conversion to Caribbean situation;

Special reference is to be made to non-traditional and renewable sources such as *biofuel and ethanol*, geothermal, solar, wind and hydro which are applicable to the Caribbean.

5.11 discuss critically mechanisms for the efficient use of energy in the Caribbean.

Emphasis should be on measures which are suited to tropical climates like the Caribbean.

**UNIT 1**  
**MODULE 1: MECHANICS (cont'd)**

**Suggested Teaching and Learning Activities**

|| *To facilitate students' attainment of the objectives of this Module, teachers are advised to engage students in teaching and learning activities listed below.* ||

1. Investigate the Physics of the motion of a cricket ball after delivery by bowler, for example, reverse swing; loop of delivery.
2. Investigate factors influencing deviation of a struck cricket ball, or any ball, from an ideal parabolic path, for example, factors such as atmospheric conditions or defects in the ball.
3. Investigate the effect of the “follow through” on the motion of struck balls in different ball sports, for example, cricket, tennis.
4. Design and construct a model for a geostationary satellite.
5. Design and construct energy conversion models, for example, solar → electricity.
6. Investigate efficiency of different energy conversion models.
7. Investigate useful energy conservation mechanisms applicable to the design and construction of buildings in the Caribbean.

**UNIT 1**  
**MODULE 1: MECHANICS (cont'd)**

**PRACTICAL ACTIVITIES**

*The teacher is urged to reinforce the relevant approved codes and safety practices during the delivery of all practical activities in the Module.*

**ARCHIMEDES' PRINCIPLE**

**Refer to Specific Objective 4.1**

**Aim:** To determine the upthrust on an object totally immersed in water.

The balance you will use, illustrated in Fig. 1, consists of a metre rule suspended by a thread from a retort stand and clamp.

**Method:** First, adjust the position of the thread on the rule so that it balances horizontally on its own with no other masses suspended. Record the position of the thread.

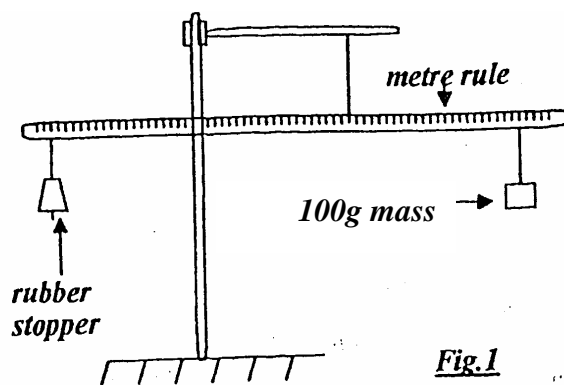

Take the RUBBER stopper provided and suspend it by a thread close to one end of the metre rule. Now balance the rule by suspending a 100g mass by a thread on the other side of the rule. The rule should be horizontal when balanced. Record the point of suspension of the 100g mass.

When the rule is balanced, the principle of moments states that the sum of the moments of forces about the point of suspension in the clockwise direction is equal to the sum of the moments in the anticlockwise direction.

Draw a diagram indicating forces acting on the rule. Write an equation for the balance of the moments of the forces. Hence, determine the mass of the stopper.

Q.1 Why balance the metre rule with nothing suspended at the start?

**UNIT 1**

## MODULE 1: MECHANICS (cont'd)

Leaving the stopper suspended from the same point, place a beaker of water below the stopper and arrange it so that the stopper is completely immersed in water. Now find a new position for suspension of the 100 g mass so that the rule is again balanced. Be careful to see that the stopper does not touch the edge or bottom of the beaker. All the results should be carefully tabulated.

From the above readings calculate the “apparent weight” of the stopper while it was immersed in water. The loss of weight is due to the upthrust of the water or “buoyancy force”. Archimedes Principle shows that:  $\text{upthrust} = \text{weight in air} - \text{apparent weight in water}$  (assuming air gives negligible upthrust). Thus, find the upthrust on the stopper.

Q.2 Does it matter how far below the surface of the water you immerse the stopper, providing you do not touch the bottom? Why?

A. Determination of upthrust on an object floating in water

Place the CORK stopper provided in a beaker of water. Note that since the cork is floating it is only partially immersed.

Q.3 What must the relation be between the upthrust on the stopper and its weight? What is this upthrust in your case? You may use the commercial balance to determine the mass of the cork.

B. Determination of the weight of water displaced by the rubber and cork stoppers

For these measurements a displacement measuring vessel (d.m.v.) is used. Place the d.m.v. on the shelf over the sink. Fill it with water until water runs out of the spout into the sink. Wait a minute or so until the water has stopped draining from the spout then place an empty beaker under the spout and carefully lower the rubber stopper into the displacement measuring vessel (d.m.v). Find the weight of the displaced water collected in the beaker. Again, wait until the water has completely stopped draining from the spout. Repeat the above procedure with the cork and find the weight of water displaced by the floating cork in the beaker.

Compare the weights of displaced water with the upthrust found in the corresponding cases in A and B above.

## UNIT 1 MODULE 1: MECHANICS (cont'd)

### THE DISTRIBUTION OF ERRORS IN PHYSICAL MEASUREMENTS

#### Refer to Specific Objective 1.7

**Aim:** To examine how errors are distributed in measurements of a physical quantity.

**Method:** The experiment is divided into three sections.

#### A. The Normal Distribution

Attach a plain sheet of paper to the soft board mounted on the wall. Make a suitable mark or marks on the paper at the level of the middle of the paper. Stand at a distance from the board and throw darts at the level on the paper where you estimate your eye level to be. According to your throwing ability several trial throws may be necessary before the most suitable throwing distance is found.

Make a total of 100 throws. More than one sheet of paper may be used (if necessary) as long as the same reference marks are used to position each. Be careful, however, otherwise your graph will be poor.

Divide the vertical range of the points on the paper(s) into 10 equal sections of the suitable width, say, for example, 2 cm. (See Figure 1). Count the number of points in each section and tabulate the results. A few points may be below section 1 or above section 10 but they should NOT be discarded. Label these sections 0, 1,..... (Note: Use a big enough sheet of paper so that your throws land on paper).

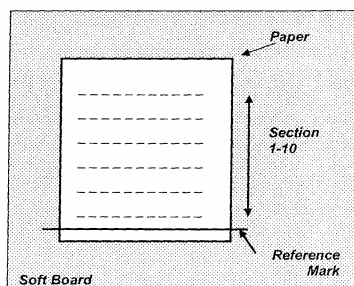

Fig. 1

Draw a histogram illustrating the number of times,  $n_i$ , that points occur in a certain section,  $x_i$  (Figure 2). Note the following about the histogram:

- Each number 0, 1,.....,10, on the  $x_i$  axis, is at the centre of a section, for example, 9 is at the centre of section 9.
- The histogram must show a section with  $n_i$  at both the start and end.
- Connect the mid-points by a smooth curve as shown. This need not go through all the midpoints.

## UNIT 1 MODULE 1: MECHANICS (cont'd)

Random errors should cause the histogram to approximately follow a bell-shaped curve called the **Normal Distribution**.

Now calculate the mean value of the measurements,  $\bar{x}$ , using the formula:

$\bar{x} = \frac{1}{N} \sum n_i x_i$  where  $N$  = total number of points and  $x_i$  can have 1 – 10. Mark the mean value  $\bar{x}$  on the histogram.

Finally, note on your paper where the mean value  $x_i$  is located and reposition your paper on the soft board. Use the meter rule provided to obtain the height of the mean value  $x_i$  above the floor.

**Example:** Suppose  $\bar{x} = 5.2$  locate the height of section 5.2 above the ground level. (It would be about 150 – 22 cm). Note that 5.0 refers to the midpoints of section 5 and 0.2 is 0.2 x the distance between the midpoints of sections 5 and 6.

Also measure directly the height of your eyes above the floor.

Comment on your results.

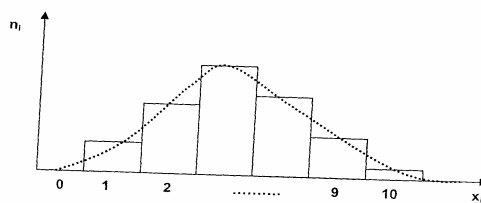

Fig. 2

### B. Standard Deviation

The degree to which numerical data are scattered about an average value is called the dispersion of the data. Common measures of the dispersion are the mean deviation and the standard deviation may be used.

If data are grouped such that  $x_1, x_2, \dots$  occur with frequencies  $n_i$   $x_i$  the following form of standard deviation may be used.

$$s = \sqrt{\frac{\sum n_i (x_i - \bar{x})^2}{N}}$$

Small values of standard deviation indicate that there is not much dispersion or scatter of the data.

- (i) For the data obtained in part (A) of the experiment calculate the standard deviation.

## UNIT 1

### MODULE 1: MECHANICS (cont'd)

(ii) Your experimental value for your eye level is, therefore,  $\bar{x} \pm s$ . Express this in terms of heights. (Remember you have already found  $\bar{x}$  from (A). **Example:** Suppose  $s = 1.4$ . If each section in your experimental sheet was 1.5 cm wide, then  $s = 1.4$  implies  $1.4 \times 1.5 = 2.1$  cm.

Your experimental value for your eye level is  $\bar{x}$  in cm  $\pm s$  in cm.

C. Repeat the experiment by standing at a longer distance ( $\frac{1}{2}$  to 2 times your previous throwing distance) away from the board. You may have to use more sheets firmly fastened together so that all your throws land on the sheets. You may also have to divide your sheets into more sections of approximately 2 cm to cover all your points.

Plot a histogram of the new results and calculate  $\bar{x} \pm s$  in cm again.

Comment on your results.

**UNIT 1**  
**MODULE 2: OSCILLATIONS AND WAVES**

**GENERAL OBJECTIVES**

On completion of this Module, students should:

1. *understand the different types of oscillatory motion;*
2. *appreciate the properties common to all waves;*
3. *recognise the unique properties of different types of waves;*
4. *apply their knowledge of waves to the functioning of the eye and the ear.*

**SPECIFIC OBJECTIVES**

**EXPLANATORY NOTES**

**1. Harmonic Motion**

Students should be able to:

- 1.1 *use the equations of simple harmonic motion to solve problems;*
- 1.2 *recall the conditions necessary for simple harmonic motion;*
- 1.3 *describe graphically the changes in displacement, velocity and acceleration with time and with displacement for simple harmonic motion;*

$$a = -\omega^2 x$$
$$x = A \sin \omega t \text{ or } x = A \cos \omega t$$
$$v = v_0 \cos \omega t \text{ or } v = v_0 \sin \omega t$$
$$v^2 = \omega^2 (A^2 - x^2) \text{ and } v_0 = \omega A$$
$$T = \frac{2\pi}{\omega}$$

**UNIT 1**



## MODULE 2: OSCILLATIONS AND WAVES (cont'd)

### SPECIFIC OBJECTIVES

### EXPLANATORY NOTES

#### Harmonic Motion (cont'd)

Students should be able to:

- |      |  |   |
|------|--|---|
| 1.4  | <i>derive and use the period of the simple pendulum as <math>T = 2\pi\sqrt{l/g}</math> and of the mass on a spring as <math>T = 2\pi\sqrt{m/k}</math>;</i> | <i>Include springs joined in series or in parallel.</i> |
| 1.5  | <i>describe the interchange of kinetic and potential energy of an oscillating system during simple harmonic motion;</i>                                    | <i>Include graphs.</i>                                  |
| 1.6  | <i>calculate the energy of a body undergoing simple harmonic motion;</i>   |   |
| 1.7  | <i>describe examples of forced oscillations and resonance;</i>   |   |
| 1.8  | <i>discuss cases in which resonance is desirable and cases in which it is not;</i>   |   |
| 1.9  | <i>describe damped oscillations and represent such motion graphically;</i>   |   |
| 1.10 | <i>explain how damping is achieved in some real-life examples.</i>   | <i>For example, motor vehicle suspension.</i>           |

#### **2. Properties of Waves**

Students should be able to:

- |     |   |  |
|-----|---|--|
| 2.1 | <i>use the following terms: displacement, amplitude, period, frequency, velocity in relation to the behaviour of waves;</i>                                     |  |
| 2.2 | <i>differentiate between transverse and longitudinal waves in terms of the movement of particles in the medium of transmission and the energy of the waves;</i> |  |

**UNIT 1**  
**MODULE 2: OSCILLATIONS AND WAVES (cont'd)**

**SPECIFIC OBJECTIVES**

**EXPLANATORY NOTES**

**Properties of Waves (cont'd)**

Students should be able to:

- |      |  |   |
|------|--|---|
| 2.3  | <i>represent transverse and longitudinal waves graphically;</i>  |   |
| 2.4  | <i>explain “polarisation” and give examples of polarised waves;</i>  | <i>Use polarisation to differentiate between transverse and longitudinal waves.</i>   |
| 2.5  | <i>derive and use the equation <math>v = f \lambda</math> to solve problems involving wave motion;</i>   |   |
| 2.6  | <i>use the relationship <b>intensity</b> is proportional to (<b>amplitude</b>)<sup>2</sup> for a wave;</i>   |   |
| 2.7  | <i>use the terms phase and phase difference with reference to behaviour of waves;</i>  |   |
| 2.8  | <i>distinguish between stationary and progressive waves;</i>   | <i>Represent graphically.</i>   |
| 2.9  | <i><u>explain the properties of stationary waves and perform related calculations;</u></i>   | <i><u>For example, microwaves, waves on strings, closed and open pipes (include resonance tube). See suggested practical activity on pages 24 and 25.</u></i> |
| 2.10 | <i>describe practical applications of sound waves in industry, such as the use of sonar waves in determining the depth of the sea, and in medicine, such as in foetal imaging;</i> |   |
| 2.11 | <i><u>discuss application of sound waves to musical instruments;</u></i>   | <i><u>Include percussion instruments such as the steel pan, stringed instruments, such as the guitar and wind instruments, such as the flute.</u></i>         |
| 2.12 | <i>apply the laws of reflection and refraction to the behaviour of waves;</i>  |   |



**UNIT 1**  
**MODULE 2: OSCILLATIONS AND WAVES (cont'd)**

**SPECIFIC OBJECTIVES**

**EXPLANATORY NOTES**

**Properties of Waves (cont'd)**

Students should be able to:

- |      |  |  |
|------|--|--|
| 2.13 | <u>describe experiments to demonstrate diffraction of waves in both narrow and wide gaps;</u>  | <u>For example, use a ripple tank together with both narrow and wide gaps, microwaves, lasers.</u>                     |
| 2.14 | <i>explain the meaning of coherence as applied to waves;</i>   |  |
| 2.15 | <i>explain the terms superposition and interference of waves;</i>  |  |
| 2.16 | <u>state the conditions necessary for two-source interference fringes of waves to be observed and perform experiments to demonstrate this;</u> | <i>For example, a simple Young's slits interference experiment for light or microwaves and two speakers for sound.</i> |
| 2.17 | <i>discuss the principles of interference and diffraction as applied to waves;</i>   | <i>Constructive and destructive interference.</i>  |
| 2.18 | <i>derive and use the approximation <math>y = \frac{\lambda D}{a}</math> to solve problems;</i>  | <i>Applies when <math>D \gg a</math> in two-source interference.</i>   |
| 2.19 | <i>use the expression <math>n\lambda = a \sin \theta</math> ; for interference and diffraction (<math>a</math>=slit spacing);</i>              | <i>For two-source interference and for diffraction grating (<math>a</math>=slit spacing).</i>                          |
| 2.20 | <u>use the diffraction grating to determine the wavelength and frequency of light waves;</u>   |  |
| 2.21 | <i>discuss the nature of light as electromagnetic radiation with reference to its diffractive properties;</i>                                  |  |
| 2.22 | <i>list the orders of magnitude of the wavelengths of the e-m spectrum;</i>  | <i>Include range of wavelengths of visible light.</i>  |
| 2.23 | <i>define refractive index in terms of velocity of waves;</i>  |  |



**UNIT 1**  
**MODULE 2: OSCILLATIONS AND WAVES (cont'd)**

**SPECIFIC OBJECTIVES**

**EXPLANATORY NOTES**

**Properties of Waves (cont'd)**

Students should be able to:

- |      |  |  |
|------|--|--|
| 2.24 | <i>use Snell's Law;</i>  | $n_1 \sin \theta_1 = n_2 \sin \theta_2$  |
| 2.25 | <i><u>explain total internal reflection and determine the value of critical angle;</u></i> | <i>See suggested practical activity on page 25.<br/><u>Use two media with indices <math>n_1</math> and <math>n_2</math>.</u></i> |
| 2.26 | <i><u>identify and discuss practical applications of total internal reflection.</u></i>    | <i>For example, fibre optic cables</i>   |

**3. Physics of the Ear and Eye**

Students should be able to:

- |     |   |  |
|-----|---|--|
| 3.1 | <i><u>discuss the response of the ear to incoming sound waves, in terms of sensitivity, frequency response and intensity;</u></i> | <i>Precise numerical values related to the response of the ear are not required.</i>       |
| 3.2 | <i>state the orders of magnitude of the threshold of hearing and the intensity at which discomfort is experienced;</i>            |  |
| 3.3 | <i>use the equation <b>intensity level (in dB) = <math>10 \log_{10} I/I_0</math></b>;</i>   | <i><math>I</math> = intensity<br/><math>I_0</math> = threshold intensity<br/>dBA scale</i> |
| 3.4 | <i>discuss the subjective qualities of the terms 'noise' and 'loudness';</i>  |  |
| 3.5 | <i>discuss the subjective qualities of the terms 'noise' and 'loudness';</i>  | <i><u>Power in dioptres = <math>1/f</math> with <math>f</math> in metres</u></i>           |
| 3.6 | <i><u>solve problems using lens formulae;</u></i>   | $1/u + 1/v = 1/f$  |
| 3.7 | <i>discuss how the eye forms focused images of objects at different distances;</i>  |  |

**UNIT 1**  
**MODULE 2: OSCILLATIONS AND WAVES (cont'd)**

**SPECIFIC OBJECTIVES**

**EXPLANATORY NOTES**

**Physics of the Ear and Eye (cont'd)**

Students should be able to:

3.8 *explain the terms 'depth of focus', 'accommodation', 'long sight', 'short sight', 'astigmatism', 'cataracts', and discuss how defects of the eye can be corrected;*

*Calculations on power of correcting lens required.*

3.9 *discuss the formation of focused images in the simple camera and magnifying glass.*

**Suggested Teaching and Learning Activities**

*To facilitate students' attainment of the objectives of this Module, teachers are advised to engage students in teaching and learning activities listed below.*

1. Find out how light is transmitted along an optical fibre. Students could investigate the effect of fibre thickness on reduction of light intensity of a specific frequency or the effect of the light frequency on loss in intensity for the identical fibre.
2. Construct a model of an electricity generator that can be powered by the energy of sea waves.
3. Construct a model of an "invisible" aircraft similar to the stealth aircraft which is constructed to be invisible to radar waves. In the stealth aircraft flat panels are angled so as to reflect incident radar signals up or down rather than back to the radar station.
4. Construct a model of the eye that demonstrates its operation and common defects. A simple laser pointer could be used as the light source.
5. Investigate the factors influencing the quality of notes produced through the vibration of waves in strings and pipes.
6. Investigate the use of ultrasonic waves in cleaning jewellery and teeth.
7. Investigate the use of ultrasonic waves in medicine.
8. Investigate the use of sonar waves.
9. Investigate the use of ultrasonics in systems, such as alarms.

**UNIT 1**  
**MODULE 2: OSCILLATIONS AND WAVES (cont'd)**

**Suggested Teaching and Learning Activities**

10. Measure the frequency response of the ear with respect to gender and age.
11. Measure the “noise” in different locations, for example, factories, airports, classrooms.
12. Gather information and present data on seismographs.
13. Investigate the design of speaker boxes and musical instruments.
14. Measure the ‘reverberation time’ in a place, such as an auditorium, church or classroom.
15. Investigate damping in shock absorbers, car mufflers, acoustic tiles.

**PRACTICAL ACTIVITIES**

***The teacher is urged to reinforce the relevant approved codes and safety practices during the delivery of all practical activities in the Module.***

*STATIONARY WAVES*

***Refer to Specific Objective 2.9***

- Aims:** (a) To investigate the properties of stationary waves.  
(b) To measure the wavelength and frequency of microwaves.  
(c) To estimate the velocity of sound in free air.

**Method:**

A. Stationary waves on a string

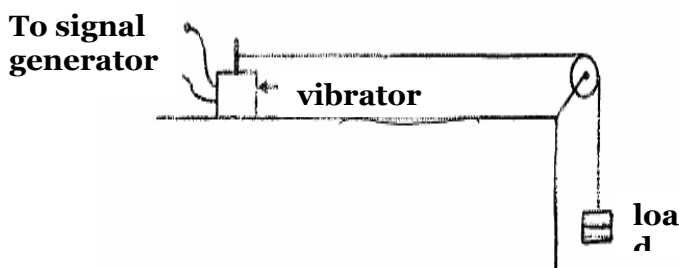

*Turn on the signal generator and find the frequency required to produce a one-loop standing wave. Then find other frequencies which give 2 loops, 3 loops .....*

**UNIT 1**  
**MODULE 2: OSCILLATIONS AND WAVES (cont'd)**



By means of a linear graph use your results to find the velocity of the waves on the string.

B. Stationary Microwaves

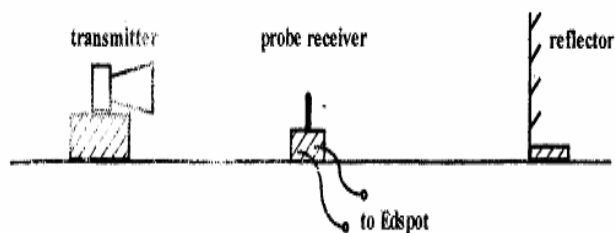

By moving the probe receiver find a number of consecutive nodes and hence measure the wave length. Explain why this is better than trying to find the distance between two nodes. Use  $c=f\lambda$  to find the frequency of the microwaves  
( $c = 3.00 \times 10^8 \text{ ms}^{-1}$ )

C. Stationary Sound Waves

(Note that this set-up will only yield an approximate value for the wavelength)

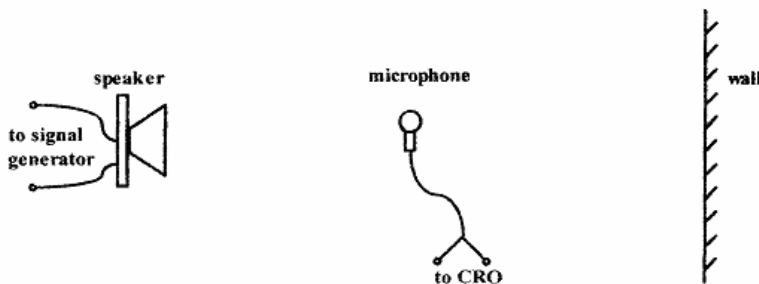

Find the distance between two consecutive nodes and, hence, find the wavelength of the sound. Find  $v$  from  $v=f\lambda$ . Repeat the experiment for a different frequency.

REFRACTION AND THE CRITICAL ANGLE

**Refer to Specific Objective 2.25**

**Aim:** To investigate the refraction of light at an air/Perspex boundary and use the data obtained to find the critical angle for light traveling from Perspex to air.

**Method:** Use pins to trace the passage of light through a semi-circular block of perspex for various angles of incidence. Note that the light is incident on the flat face and you must look at the alignment of the pins through the curved surface. [If available a light box could be used to trace the rays instead of pins]

UNIT 1

## MODULE 2: OSCILLATIONS AND WAVES (cont'd)

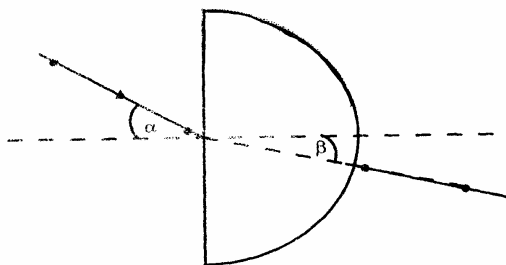

*It is important that you take care in setting up the apparatus: if the incident ray does not go through the centre of the circle then the refracted ray will bend again at the curved surface.*

*Plot a graph of  $\beta$  against  $\alpha$  and extend the graph to find the value of  $\beta$  when  $\alpha$  is  $90^\circ$ .*

*Also plot a linear graph with the same data and obtain a second value for the critical angle.*

*In your summary comment on the relative merits of the two alternative ways of handling the data.*

## UNIT 1

### MODULE 3: THERMAL AND MECHANICAL PROPERTIES OF MATTER

#### GENERAL OBJECTIVES

On completion of this Module, students should:

1. understand the principles involved in the design and use of thermometers;
2. be aware of the thermal properties of materials and their practical importance in everyday life;
3. understand the various modes of heat transfer;
4. be familiar with the kinetic theory of gases and the equation of state of an ideal gas;
5. *display* a working knowledge of the first law of thermodynamics;
6. be aware of the mechanical properties of materials and their practical importance in everyday life.

#### SPECIFIC OBJECTIVES

##### 1. Design and Use of Thermometers

Students should be able to:

- 1.1 discuss how a physical property may be used to measure temperature;
- 1.2 *describe the physical features of specific thermometers;*
- 1.3 discuss the advantages and disadvantages of these thermometers;
- 1.4 recall that the absolute thermodynamic scale of temperature does not depend on the property of any particular substance;
- 1.5 determine temperatures in kelvin, in degrees Celsius and on the empirical centigrade scales.

#### EXPLANATORY NOTES

Include both linear and non-linear variation with temperature.

*Liquid-in-glass, resistance (including thermistor), thermocouple and constant volume gas thermometer.*

*Empirical scale*

$$\theta = \frac{x_{\theta} - x_0}{x_{100} - x_0} \times 100^{\circ}\text{C}$$

*Kelvin scale*

$$T = \frac{P_t}{P_{tr}} \times 273.16 \text{ K}$$

$$\theta/^{\circ}\text{C} = T/\text{K} - 273.15$$

## UNIT 1

### MODULE 3: THERMAL AND MECHANICAL PROPERTIES OF MATTER (cont'd)

#### SPECIFIC OBJECTIVES

#### EXPLANATORY NOTES

#### 2. Thermal Properties

Students should be able to:

- 2.1 express the internal energy of a system as the sum of the kinetic and potential energies associated with the molecules of the system;
- 2.2 relate a rise in temperature to an increase in internal energy;
- 2.3 *explain* the terms 'heat capacity' and 'specific heat capacity';
- 2.4 perform experiments to determine the specific heat capacity of liquids and metals  
by electrical methods and by the method of mixtures;
- 2.5 explain the concepts of 'melting' and 'boiling' in terms of energy input with no change in temperature;
- 2.6 relate the concepts of melting and boiling to changes in internal potential energy;
- 2.7 *explain* the term 'specific latent heat';
- 2.8 use graphs of temperature against time to determine freezing or melting points and boiling points;

Both electrical methods and the method of mixtures are to be covered.

## UNIT 1

### MODULE 3: THERMAL AND MECHANICAL PROPERTIES OF MATTER (cont'd)

#### SPECIFIC OBJECTIVES

#### EXPLANATORY NOTES

##### Thermal Properties (cont'd)

Students should be able to:

- 2.9 perform experiments to determine the specific latent heats;
- 2.10 explain the cooling which accompanies evaporation;
- 2.11 solve numerical problems using the equations  $E_H = mc \Delta\theta$  and  $E_H = mL$ .

Both electrical methods and the method of mixtures are to be covered. See *suggested practical activity on page 34.*

This should be done in terms of latent heat and in terms of the escape of molecules with high kinetic energy.

##### **3. Heat Transfer**

Students should be able to:

- 3.1 describe the mechanism of thermal conduction;
- 3.2 use the equation  $\frac{Q}{t} = -kA \frac{\Delta\theta}{\Delta x}$  to solve problems in one-dimensional heat flow;
- 3.3 solve numerical problems involving composite *conductors*;
- 3.4 discuss the principles involved in the determination of thermal conductivity of good and bad conductors;
- 3.5 explain the process of convection as a consequence of a change of density, and use this concept to explain ocean currents and winds;

Restrict use to cases of one-dimensional heat flow.

*Use of concept of equivalent conductor.*

## UNIT 1

### MODULE 3: THERMAL AND MECHANICAL PROPERTIES OF MATTER (cont'd)

#### SPECIFIC OBJECTIVES

#### EXPLANATORY NOTES

##### Heat Transfer (cont'd)

Students should be able to:

- 3.6 discuss thermal radiation and solve problems using Stefan's equation;
- 3.7 explain the greenhouse effect;
- 3.8 discuss applications of the transfer of energy by conduction, convection and radiation;
- 3.9 discuss the development of heating and cooling systems to reduce the Caribbean dependency on fossil fuels.

*For a black body  $P=A\sigma T^4$ . Include net rate of radiation.*

Include vacuum flasks and solar water heaters.

#### 4. The Kinetic Theory of Gases

Students should be able to:

- 4.1 use the equation of state for an ideal gas expressed as  $pV = nRT$ , and  $pV = NkT$ ;
- 4.2 discuss the basic assumptions of the kinetic theory of gases;
- 4.3 explain how molecular movement is responsible for the pressure exerted by a gas;
- 4.4 derive and use the equation  $pV = \frac{1}{3}Nmc^2$ ;
- 4.5 use  $pV = \frac{1}{3}Nmc^2$  to deduce the equation for the average translational kinetic energy of monatomic molecules;

*Include calculations of r.m.s. speed,  $\overline{c^2}$  or  $\langle c^2 \rangle$*

$$E_k = \frac{3}{2}kT$$

## UNIT 1

### MODULE 3: THERMAL AND MECHANICAL PROPERTIES OF MATTER (cont'd)

#### SPECIFIC OBJECTIVES

#### EXPLANATORY NOTES

#### The Kinetic Theory of Gases (cont'd)

Students should be able to:

4.6 deduce total kinetic energy of a monatomic gas.

$$\text{Total kinetic energy } E_k = \frac{3}{2} nRT$$

#### 5. First Law of Thermodynamics

Students should be able to:

5.1 use the term 'molar heat capacity';

$$E_H = n C_v \Delta\theta \text{ or } E_H = n C_p \Delta\theta$$

5.2 discuss why the molar heat capacity of a gas at constant volume is different from that of a gas at constant pressure;

$$C_p = C_v + R$$

5.3 calculate the work done on a gas using the equation  $W = p \Delta V$ ;

5.4 deduce work done from a **p-V** graph;

5.5 express the first law of thermodynamics in terms of the change in internal energy, the heat supplied to the system and the work done on the system;

$$\Delta U = Q + W$$

5.6 solve problems involving the first law of thermodynamics.

## UNIT 1

### MODULE 3: THERMAL AND MECHANICAL PROPERTIES OF MATTER (cont'd)

#### SPECIFIC OBJECTIVES

#### EXPLANATORY NOTES

#### 6. Mechanical Properties of Materials

Students should be able to:

6.1 *explain and* use the terms 'density' and 'pressure';

$$p = F/A \quad \rho = M/V$$

6.2 derive and use the equation  $\Delta p = \rho g \Delta h$  for the pressure difference in a liquid;

6.3 relate the difference in the structures and densities of solids, liquids and gases to simple ideas of the spacing, ordering and motion of their molecules;

6.4 describe a simple kinetic model for the behaviour of solids, liquids and gases;

6.5 distinguish between the structure of crystalline and non-crystalline solids, with particular reference to metals, polymers and glasses;

Make particular reference to metals, polymers and glasses.

6.6 *discuss the stretching of springs and wire in terms of load extension;*

*Hooke's law*  
*Spring constant*

6.7 use *the relationship among* 'stress', 'strain' and 'the Young modulus' to solve problems;

$$E = \frac{\text{stress}}{\text{strain}}$$

6.8 perform experiments to determine the Young modulus of a metal in the form of a wire;

6.9 demonstrate knowledge of the force-extension graphs for typical ductile, brittle and polymeric materials;

For example, copper, glass, rubber.

6.10 deduce the strain energy in a deformed material from a force-extension graph;

## UNIT 1



## MODULE 3: THERMAL AND MECHANICAL PROPERTIES OF MATTER (cont'd)

### SPECIFIC OBJECTIVES

### EXPLANATORY NOTES

#### Mechanical Properties of Materials (cont'd)

Students should be able to:

6.11 distinguish between elastic and inelastic deformations of a material;

Only qualitative knowledge is required.

See suggested practical activity on page 35.

6.12 discuss the importance of elasticity in structures.

Consider what happens to tall buildings, bridges and bones when large forces are applied.

#### Suggested Teaching and Learning Activities

To facilitate students' attainment of the objectives of this Module, teachers are advised to engage students in teaching and learning activities listed below.

1. Investigate how three different physical properties vary with temperature.
2. Investigate the suitability of using iron, copper or aluminum as the metal used for making an engine block.
3. Investigate the heat flow through different materials of the same thickness and recommend the use of one in the construction industry, for example, brick, concrete, glass and wood.
4. Investigate this statement: heat flow in textiles can occur by all three methods of heat transfer, but for metals only conduction is possible.
5. Investigate the effect of greenhouse gases on global warming.
6. Investigate heat transfer processes in the solar water heater.
7. Construct a model of a solar crop dryer.
8. Construct a model of a solar air conditioner.
9. Construct a model of a solar still.
10. Construct a model of a solar refrigerator.
11. Investigate the role of thermodynamics in the operation of the four-stroke petrol engine.

### UNIT 1

## MODULE 3: THERMAL AND MECHANICAL PROPERTIES OF MATTER (cont'd)



12. Investigate the uses of crystalline and non-crystalline solids in the semiconductor industry.
13. Investigate the uses of polymers and glasses.
14. Investigate force-extension graphs for metal wires, glass fibres and rubber.

### **PRACTICAL ACTIVITIES**

**The teacher is urged to reinforce the relevant approved codes and safety practices during the delivery of all practical activities in the Module.**

#### **LATENT HEAT**

#### **Refer to Specific Objective 2.9**

**Aim:** To determine:

- (i) the specific latent heat of vaporization of a liquid by an electrical method: and
- (ii) the specific latent heat of fusion of ice by the method of mixtures.

**Method:** (a) The more sophisticated apparatus in the text may not be available, in which case the apparatus shown below can be used. The principle is the same. The energy supplied after the liquid has started to boil is equal to the heat required to boil off a mass  $n$  of liquid plus the heat to the surroundings,  $H$ , that is,  $VIt = mL + H$ .

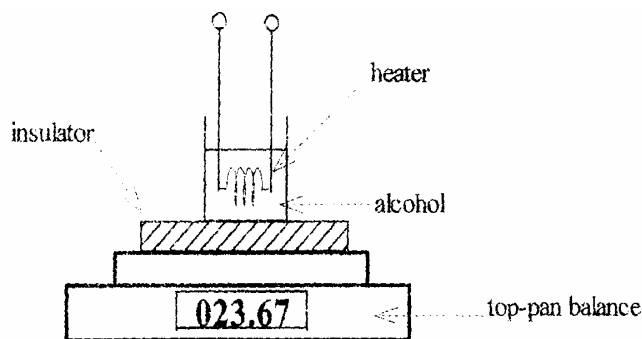

If the procedure is repeated with different values of  $V$  and  $I$  but with the same time,  $t$ , then the last term may be eliminated by subtraction. (Explain why the heat loss is the same in both cases, provided the time is the same).

## UNIT 1

### MODULE 3: THERMAL AND MECHANICAL PROPERTIES OF MATTER (cont'd)

- (b) A Styrofoam cup, which has a negligible heat capacity, is to be used as the calorimeter.

Carefully consider the possible errors in this method before starting. A good way of reducing the effect of the surroundings is to start the experiment with the water in the cup above room temperature and add small pieces of dried ice until the temperature is same amount below room temperature.

#### STRETCHING GLASS AND RUBBER

##### Refer to Specific Objective 6.11

- Aims:**
- (a) To compare the breaking stress of glass with that of rubber.
  - (b) To investigate the behaviour of rubber when it is loaded and unloaded.

**Method:** **Stretching glass could be dangerous so this part of the experiment will be performed by the laboratory assistant. Warning: BE VERY CAREFUL with the glass. Do not have your eyes near it at any time.**

You will be provided with a piece of rubber band. Add loads to it until it breaks and make other necessary measurements so that you can work out the breaking stress.

Using a similar piece of rubber to that in (a) add masses in 100 g increments until the load is 300 g less than the maximum. For each load measure the extension of the rubber. Continue measuring the extension as the load is removed. Plot a graph to illustrate your results.

**Note:** It is best not to measure the length of the rubber between the support and the knot because the rubber might slip. Instead use two fine ink marks drawn on the band.

(Preparation: Glass rod is heated and a hook made. Then it is heated in the centre and stretched to produce a thin section.)

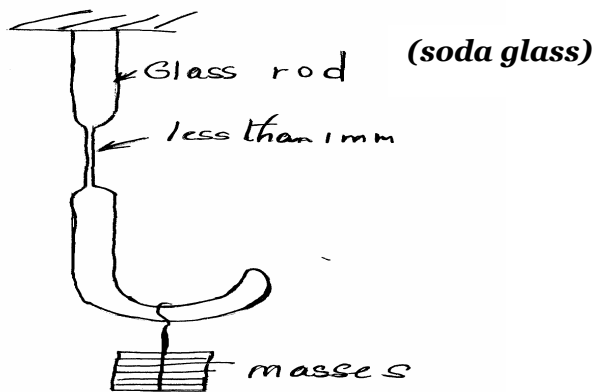

## ♦ UNIT 2: ELECTRICITY AND MAGNETISM, A. C. THEORY AND ELECTRONICS, ATOMIC AND NUCLEAR PHYSICS

### MODULE 1: ELECTRICITY AND MAGNETISM

#### GENERAL OBJECTIVES

On completion of this Module, students should:

1. understand electrostatic phenomena;
2. understand electrical quantities and the relationships among them;
3. *analyse* circuits with various electrical components;
4. understand the concept of electric fields;
5. *be aware of the design and use of capacitors*;
6. demonstrate a conceptual understanding of magnetic fields;
7. *understand how* magnetic forces arise;
8. demonstrate a working knowledge of electromagnetic phenomena.

#### SPECIFIC OBJECTIVES

#### EXPLANATORY NOTES

##### 1. Electrical Quantities

Students should be able to:

- 1.1 use the equation  $Q = It$  to solve problems;
- 1.2 define the 'coulomb';
- 1.3 define the 'volt';
- 1.4 use the equation  $V = W/Q$  to solve problems;
- 1.5 use the equation  $V = IR$  to solve problems;

## UNIT 2

### MODULE 1: ELECTRICITY AND MAGNETISM (cont'd)

#### SPECIFIC OBJECTIVES

#### EXPLANATORY NOTES

#### Electrical Quantities (cont'd)

1.6 use the equations  $P = IV$ ,  $P = I^2R$ ,  $P = V^2/R$  to solve problems;

1.7 define and use the term resistivity;

$$R = \frac{\rho L}{A}$$

1.8 use energy considerations to distinguish between e.m.f. and p.d.;

Include the observation that e.m.f is associated with sources or active devices whereas p.d. is used in reference to an electric field or passive device.

1.9 explain drift velocity ( $v$ );

1.10 derive and use the equation  $I = nevA$  for electrons moving in a metal ( $n =$  charge density).

Since a similar equation describes the flow of particles in uniform channels, candidates should be able to apply such equations to semiconductors and electrolytes.

#### 2. Electrical Circuits

Students should be able to:

2.1 sketch the I - V characteristic for a metallic conductor at constant temperature, a semiconductor diode, and a filament lamp;

Explain these characteristics in terms of the variation in resistance of the device.

2.2 sketch the variation of resistance with temperature for a thermistor with negative temperature co-efficient;

Also include different types of thermistors and discuss the differences between the R - T characteristics.

2.3 solve problems involving terminal p.d. and external load, given that sources of e.m.f. possess internal resistance;

Use examples of different types of source, for example, primary and secondary chemical cells, solar cells, generators.

2.4 draw and interpret circuit diagrams;

Consider d.c. circuits involving sources of e.m.f. and resistive circuit elements.

## UNIT 2

### MODULE 1: ELECTRICITY AND MAGNETISM (cont'd)

#### SPECIFIC OBJECTIVES

#### EXPLANATORY NOTES

#### Electrical Circuits (cont'd)

Students should be able to:

2.5 apply Kirchhoffs laws to given circuits;

*Kirchhoff's First Law is a consequence of conservation of charge and Kirchhoff's Second Law, a consequence of conservation of energy.*

2.6 derive and use the formula for the effective resistance of two or more resistors in series;

2.7 derive and use the formula for two or more resistors in parallel;

2.8 use the potential divider as a source of variable and fixed p.d.;

2.9 use the Wheatstone bridge as a means of comparing resistances.

*Treat as a double potential divider.*

#### 3. Electric Fields

Students should be able to:

3.1 *explain the difference between electrical conductors and insulators;*

*An electron model should be used in the explanation.*

3.2 *discuss simple practical applications of electrostatic phenomena, such as agricultural spraying and dust extraction;*

*Additional examples can be drawn from more modern devices such as electrostatic copiers and laser printers.*

3.3 *discuss hazards associated with charging by friction;*

*Mention the magnitudes of the physical quantities involved.*

3.4 *explain the action of lightning rods in the protection of buildings;*

*Requires only a simple explanation of how a gas breaks down and begins to conduct when subjected to very high electric fields.*

## UNIT 2

### MODULE 1: ELECTRICITY AND MAGNETISM (cont'd)

#### SPECIFIC OBJECTIVES

#### EXPLANATORY NOTES

#### Electric Fields (cont'd)

Students should be able to:

3.5 use Coulomb's Law for the force between charges in free space or air to solve problems;

Consider combinations of charges arranged in very simple arrangements. Use a vector approach to determine the resultant force on a single point charge due to other point charges.

3.6 use  $E = \frac{Q}{4\pi\epsilon_0 r^2}$  for the field strength due to a point charge;

$E$  is a vector.

3.7 calculate the field strength of the uniform field between charged parallel plates, in terms of potential difference and separation of the plates;

$$E = \frac{V}{d}$$

3.8 calculate the force on a charged particle in a uniform electric field;

$$F = EQ$$

3.9 describe the effect of a uniform electric field on the motion of charged particles;

Consider motions perpendicular and parallel to the electric field.

3.10 solve numerical problems involving the motion of charged particles in a uniform electric field *and compare this motion to that of a projectile in a gravitational field*;

3.11 use the fact that the field strength at a point is numerically equal to the potential gradient at that point;

Consider the uniform electric field and by determining the work done per unit charge, verify this relationship. *Refer to Specific Objective 3.7*

3.12 use the equation  $V = \frac{Q}{4\pi\epsilon_0 r}$  for the potential due to a point charge;

Compare the potential due to a point charge with that due to a charged sphere of radius  $r$ .  
 $V$  is a scalar.

## UNIT 2

### MODULE 1: ELECTRICITY AND MAGNETISM (cont'd)

#### SPECIFIC OBJECTIVES

##### Electric Fields (cont'd)

Students should be able to:

- 3.13 find the potential at a point due to several charges.

##### 4. Capacitors

Students should be able to:

- 4.1 explain the 'farad';
- 4.2 use  $C = Q/V$  to solve problems;
- 4.3 use the formula  $C = \frac{\epsilon A}{d}$ ;
- 4.4 derive and use formulae for capacitors in parallel and series to solve problems;
- 4.5 use the energy stored in a capacitor as  $W = \frac{CV^2}{2}$ ,  $W = \frac{QV}{2}$  and  $W = \frac{Q^2}{2C}$  to solve problems;
- 4.6 recall and use the equations for capacitor discharge;

#### EXPLANATORY NOTES

*Contrast with vector addition in Specific Objectives 3.5 and 3.6.*

*Refer to the use of dielectrics to produce capacitors of larger values with the same dimensions. Mention the types of dielectrics and the range of their dielectric constants or relative permittivity.*

*Include problems on equivalent capacitance for simple series parallel combinations.*

*Discuss the mechanism of energy storage in a capacitor.*

$$Q = Q_0 \exp\left(\frac{-t}{RC}\right)$$

$$I = I_0 \exp\left(\frac{-t}{RC}\right)$$

$$V = V_0 \exp\left(\frac{-t}{RC}\right)$$

*(RC is the "time constant" and measured in seconds.)*



## UNIT 2

### MODULE 1: ELECTRICITY AND MAGNETISM (cont'd)

||

#### SPECIFIC OBJECTIVES

#### EXPLANATORY NOTES

##### Capacitors (cont'd)

Students should be able to:

4.7 sketch graphs illustrating the charge and discharge of a capacitor.

Q, V or I against t.

##### 5. Magnetic Fields

Students should be able to:

5.1 explain 'magnetic flux density' and the 'tesla';

5.2 sketch magnetic flux patterns due to a long straight wire, a flat circular coil and a long solenoid;

5.3 use the expressions for the magnetic flux density of a distance r from a long straight wire, the centre of a flat circular coil and near the centre of a long solenoid, respectively.

$$B = \frac{\mu_0 I}{2\pi r}, B = \frac{\mu_0 NI}{2r}, B = \mu_0 nI$$

See suggested practical activities on page 44.

##### 6. Magnetic Forces

Students should be able to:

6.1 use Fleming's Left-Hand Rule to predict the direction of the force on a current-carrying conductor;

6.2 use the equation  $F = BIL \sin \theta$  to solve problems;

6.3 explain how the force on a current-carrying conductor can be used to measure the flux density of a magnetic field by means of a current balance;

See suggested practical activity on page 45.



## UNIT 2

### MODULE 1: ELECTRICITY AND MAGNETISM (cont'd)

||

#### SPECIFIC OBJECTIVES

#### EXPLANATORY NOTES

##### Magnetic Forces (cont'd)

Students should be able to:

6.4 predict the direction of the force on a charge moving in a magnetic field;

*Use Fleming's Left-Hand Rule and treat the moving charge as an electric current.*

*Qualitative discussion of the trapping of charged particles by magnetic fields with specific mention of earth's magnetic field and the Van Allen radiation belt.*

6.5 use the expression  $F = BQv\sin \theta$  to solve problems;

6.6 solve problems involving charged particles moving in mutually perpendicular electric and magnetic fields;

6.7 describe the effect of a soft iron core on the magnetic field due to a solenoid;

Compare this effect with that of the dielectric in a capacitor.

6.8 explain the principle of the electromagnet and discuss its uses in doorlocks, switches and other applications;

6.9 explain the origin of the forces between current-carrying conductors, and predict the direction of the forces;

6.10 explain the Hall effect;

*In developing the explanation, refer to Specific Objective 6.5*

6.11 use the Hall probe to measure flux density.

## UNIT 2

### MODULE 1: ELECTRICITY AND MAGNETISM (cont'd)

#### SPECIFIC OBJECTIVES

#### EXPLANATORY NOTES

#### 7. Electromagnetic Induction

Students should be able to:

7.1 *explain magnetic flux and use the equation*  
 $\Phi = \mathbf{BA}$  to solve problems;

7.2 *explain the 'weber';*

7.3 describe and interpret experiments which demonstrate the relationship between the magnitude and direction of an induced e.m.f. and the change of flux linkage producing the e.m.f.;

Explain separately and qualitatively the effects obtained when:

- (a) bar magnet moves inside a solenoid;
- (b) two flat coils move with respect to each other;
- (c) bar magnet moves with respect to flat coil;
- (d) one solenoid moves inside another;
- (e) solenoid moves inside a flat coil.

In your explanation, refer to Specific Objective 7.5.

7.4 use Faraday's Law of electromagnetic induction to determine the magnitude of an induced e.m.f.;

*See suggested practical activity on page 46.*

*Include  $E = BLv$  for a straight conductor.*

7.5 use Lenz's Law to determine the direction of an induced e.m.f.;

7.6 discuss Lenz's Law as an example of conservation of energy;

7.7 explain simple applications of electromagnetic induction;

Transformers, ac and dc motors and generators should be discussed as major applications of electromagnetic induction.

7.8 explain the principle of operation of the simple transformer;





## UNIT 2

### MODULE 1: ELECTRICITY AND MAGNETISM (cont'd)

||

#### SPECIFIC OBJECTIVES

#### EXPLANATORY NOTES

#### Electromagnetic Induction (cont'd)

Students should be able to:

- 7.9 *use the relationship*  $\frac{N_s}{N_p} = \frac{V_s}{V_p} = \frac{I_p}{I_s}$   
*for the ideal transformer.*

#### Suggested Teaching and Learning Activities

To facilitate students' attainment of the objectives of this Module, teachers are advised to engage students in Practical Activities outlined below.

#### **PRACTICAL ACTIVITIES**

**The teacher is urged to reinforce the relevant approved codes and safety practices during the delivery of all practical activities in the Module.**

#### **THE MAGNETIC FIELD OF A SOLENOID**

#### **Refer to Specific Objective 5.3**

**Aim:** To investigate the factors affecting the magnetic flux density of a solenoid.

This experiment uses a Hall probe and a direct current flowing in the solenoid. The reading on the voltmeter connected to the probe is directly proportional to  $B$ . Sometimes, the meter is already calibrated in mT but usually a conversion factor is used.

**Method:** (a) Two of the solenoids provided have the same area and length but a different number of turns (which is marked on them). Ensuring that the currents are the same in each by connecting them in series, investigate how  $B$  at the centre of the solenoid depends on  $n$ , the turn concentration, for at least three different current values.

Also move the probe from side to side to see how the field varies across the solenoid.

- (b) Choose a pair of solenoids with the same number of turns per unit length,  $n$ , but different areas and investigate how  $B$  depends on the area of cross-section when the other factors are kept constant. Repeat with different currents.
- (c) Investigate how the field at the centre of a solenoid depends on the current flowing in it.

*Find  $B$  at various positions along the solenoid axis and plot a graph to display your results.*

UNIT 2  
MODULE 1: ELECTRICITY AND MAGNETISM (cont'd)

FORCE ON CURRENT-CARRYING CONDUCTOR

Refer to Specific Objective 6.3

**Aim:** To test the relationship  $F=BIL$  for the force on a current-carrying conductor.

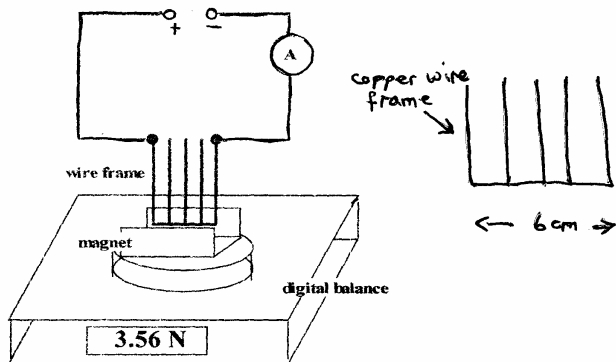

**Method:** Set up the apparatus shown above so that an upward force will be exerted on the wire when the current is flowing. Before switching on, press the tare bar on the balance to set the reading at zero.

Since the conductor is forced upward, an equal and opposite force will push the magnet down (Newton III) so the force on the wire may be calculated from the balance reading.

According to the texts, the force on a current-carrying wire AT RIGHT ANGLES to a uniform field is:

- (a) proportional to the current,  $I$ , flowing in the conductor;
- (b) proportional to the length,  $L$ , of the conductor.

Use this apparatus to test these two statements.

Also use both sets of data to find the proportionally constant  $B$  (known as the flux density of the uniform field) in the relationship,  $F=BIL$ .

## UNIT 2

### MODULE 1: ELECTRICITY AND MAGNETISM (cont'd)

#### THE LAWS OF ELECTROMAGNETIC INDUCTION

##### Refer to Specific Objective 7.4

**Aim:** To test the Faraday relationship: induced e.m.f. equals the rate of change of magnetic flux linkage.

$$E = NA \frac{dB}{dt}$$

##### Theory

Flux linkage =  $NAB$  where  $N$  is the number of turns in the secondary coil,  $A$  is the area of the coil and  $B$  is the magnetic flux density produced by the primary coil.

To investigate the relationship above, two of the quantities must remain constant while the third is varied. (Note that the rate of change of  $B$  depends on the rate of change of  $I$  which is proportional to the frequency).

**Apparatus:** Pair of solenoids of square cross-section; one has twice the area of the other.

**Signal generator:** use the low impedance output and set the frequency on the 100 to 1000 Hz range.

Cathode ray oscilloscope for measuring the peak induced voltage.

A.C. ammeter to ensure that the current is constant (so that  $B$  is constant).

Long length of insulated copper wire to wind various numbers of turns on the solenoids.



**UNIT 2**  
**|| MODULE 2: A.C. THEORY AND ELECTRONICS**

||

**GENERAL OBJECTIVES**

On completion of this Module, students should:

1. understand the principles and operation of the p-n junction diode;
2. understand the characteristics of alternating currents and their applications;
3. understand the use of transducers as input and output devices;
4. understand *the use of* operational amplifiers *in analogue circuits*;
5. demonstrate proficiency *in the use of* logic gates in digital circuits.

**SPECIFIC OBJECTIVES**

**EXPLANATORY NOTES**

**1. Alternating Currents**

Students should be able to:

- 1.1 use the terms 'frequency', 'peak value' and 'root-mean-square value' in relation to an alternating current or voltage;
- 1.2 use an equation of the form  $x = x_0 \sin \omega t$  to represent an alternating current or voltage;
- 1.3 use the relationship that the peak value is  $\sqrt{2}$  times the r.m.s. value for the sinusoidal case;
- 1.4 discuss the advantages of using alternating current and high voltages for the transmission of electrical energy.

Students should recognize that ac voltages and currents are commonly quoted in terms of the rms values.

## UNIT 2

### MODULE 2: A.C. THEORY AND ELECTRONICS (cont'd)

||

#### SPECIFIC OBJECTIVES

#### EXPLANATORY NOTES

#### 2. The p-n Junction Diode

Students should be able to:

2.1 describe the electrical properties of semiconductors and distinguish between p-type and n-type material;

The population density of holes and electron in intrinsic and doped semiconductors should be mentioned and compared with that for conductors.

Resistivity of semiconductors should be compared to that of conductors in order to place the values in meaningful contexts.

2.2 explain the formation of a depletion layer at a p-n junction;

The fact that a depletion layer forms in the unbiased p-n junction should be emphasized.

2.3 discuss the flow of current when the p-n junction diode is forward-biased or reverse-biased;

2.4 discuss the I-V characteristic of the p-n junction diode;

Mention some applications of diodes and show how these simple characteristics lead to these applications.

2.5 *recall that a junction transistor is basically two p-n junctions;*

*Draw a diagram and also draw the transistor symbol.*

2.6 use the diode for half-wave rectification;

2.7 use the bridge rectifier (4 diodes) for full-wave rectification;

2.8 *represent half-wave and full-wave rectification graphically;*

2.9 discuss the use of a capacitor for smoothing a rectified ac wave.

Include significance of the time-constant RC.



**UNIT 2**  
**|| MODULE 2: A.C. THEORY AND ELECTRONICS (cont'd)**

||

**SPECIFIC OBJECTIVES**

**EXPLANATORY NOTES**

**3. Transducers**

Students should be able to:

3.1 explain the use of the light-dependent resistor (LDR), the thermistor and the microphone as input devices *for electronic circuits*;

*Used if necessary in a potential divider or in a Wheatstone bridge circuit.*

3.2 *describe* the operation of the light-emitting diode (LED), the buzzer and the relay as output devices.

*Include use of protective resistor for the LED.*

**4. Operational Amplifiers**

Students should be able to:

4.1 describe the properties of the ideal operational amplifier;

Infinite input impedance, infinite *open loop* gain, zero output impedance.

4.2 compare the properties *of a real operational amplifier* with the ideal operational amplifier;

4.3 use the operational amplifier as a comparator;

*For example, converting sine wave to square wave, turning on an alarm when the temperature exceeds a fixed value.*

4.4 use the fact that magnitude of the output voltage cannot exceed that of the power supply;

*Introduce “clipping” and “saturation”.*

4.5 explain the meaning of gain and bandwidth of an amplifier;

Typical as well as ideal values for these quantities should be discussed.

4.6 explain the gain-frequency curve for a typical operational amplifier;

Include the fact that *gain and frequency are* usually plotted on logarithmic *axes* and explain the reason for this.

4.7 determine bandwidth from a gain-frequency curve;

Precise numerical values related to the response of the ear are not required.



## UNIT 2

### MODULE 2: A.C. THEORY AND ELECTRONICS (cont'd)

||

#### SPECIFIC OBJECTIVES

#### EXPLANATORY NOTES

#### Operational Amplifiers (cont'd)

Students should be able to:

- |      |  |  |
|------|--|--|
| 4.8  | draw the circuit diagram for both the inverting and non-inverting amplifier with a single input;   | Students should be familiar with several representations of the same circuit.  |
| 4.9  | use the concept of virtual earth in the inverting amplifier;   | Explain why the virtual earth cannot be connected directly to earth although it is “virtually” at earth potential.                               |
| 4.10 | derive and use expressions for the gain of both the inverting amplifier <i>and the non-inverting amplifier</i> ;                             | <i>Use the properties of the ideal op-amp.</i>   |
| 4.11 | <u>discuss the effect of negative feedback on the gain and bandwidth of an inverting operational amplifier and non-inverting amplifier</u> ; | <u>Mention the effect of negative feedback on other op-amp characteristics.</u><br><i>See suggested practical activities on pages 54 and 55.</i> |
| 4.12 | perform calculations related to single-input amplifier circuits;   | Include “cascaded” amplifiers.   |
| 4.13 | <i>use the fact that a non-inverting amplifier has a very high input impedance</i> ;   |  |
| 4.14 | <u>describe the use of the inverting amplifier as a summing amplifier</u> ;  | <u>Mention of practical uses of summing amplifier, for example, mixing boards.</u>   |
| 4.15 | solve problems related to summing amplifier circuits;  | <i>Relate to the use of summing amplifier as a digital to analogue convert.</i>  |
| 4.16 | <u>describe the use of the operational amplifier as a voltage follower</u> ;   | <u>Mention the important practical use of the voltage follower as a buffer or matching amplifier.</u>  |

## UNIT 2

### || MODULE 2: A.C. THEORY AND ELECTRONICS (cont'd) ||

#### SPECIFIC OBJECTIVES

#### EXPLANATORY NOTES

#### Operational Amplifiers (cont'd)

Students should be able to:

- 4.17 analyse simple operational amplifier circuits;
- 4.18 analyse the response of amplifier circuits to input signals, using timing diagrams.

#### 5. Logic Gates

Students should be able to:

- 5.1 describe the function of the following logic gates: NOT, AND, NAND, OR, NOR, EXOR, EXNOR;
- 5.2 use truth tables to represent the function of logic gates with no more than two inputs;
- 5.3 *re-design a logic circuit to contain only NOR gates or only NAND gates;*
- 5.4 analyse circuits using combinations of logic gates to perform control functions;
- 5.5 construct and interpret truth tables for a combination of logic gates;
- 5.6 *use timing diagrams to represent the response of digital circuits to different input signals;*

Include the equivalence relationship between different gates, *for example, AND from NORS, OR from NANDS, NOR from OR+NOT, NOT from NOR.*

*Circuit should be reduced to minimum chip count.*

Students should familiarise themselves at the earliest possible opportunity with the application of logic gates to solve simple real world problems and a familiar practical example should be described.

## UNIT 2

### || MODULE 2: A.C. THEORY AND ELECTRONICS (cont'd) ||

#### SPECIFIC OBJECTIVES

#### EXPLANATORY NOTES

#### Logic Gates (cont'd)

Students should be able to:

- |      |  |  |
|------|--|--|
| 5.7  | <i>draw a circuit to show the construction of a half-adder and explain its operations;</i> | <i>From two NORs and an AND or from EXOR and an AND.</i>     |
| 5.8  | <i>use two half-adders and an OR to construct a full-adder;</i>                            |  |
| 5.9  | <i>explain the operation of a flip-flop consisting of two NAND gates or two NOR gates;</i> | <i>Use of the S-R flip-flop as a latch or memory.</i>        |
| 5.10 | <i>describe the operation of the triggered bistable;</i>                                   |  |
| 5.11 | <i>combine triggered bistables (T flip-flops) to make a 3-bit binary counter;</i>          |  |
| 5.12 | <u>discuss the application of digital systems in the home and in industry.</u>             | <u>Automobile applications can also be used as examples.</u> |

#### Suggested Teaching and Learning Activities

|| *To facilitate students' attainment of the objectives of this Module, teachers are advised to engage students in teaching and learning activities listed below.* ||

1. Measure the I-V characteristics of different p-n junction diodes.
2. Construct and test half-wave and full-wave rectification circuits.
3. Investigate the smoothing effect of a capacitor on a rectified ac wave.
4. Measure the response of LDRs, thermistors and microphones to different inputs.
5. Investigate the response of LEDs, buzzers and relays to output signals.
6. Construct and test comparator circuits using operational amplifiers.
7. Measure the bandwidth of an operational amplifier circuit and determine the effect of negative feedback on bandwidth.

## UNIT 2



## || MODULE 2: A.C. THEORY AND ELECTRONICS (cont'd) ||

||

8. Construct simple amplifier circuits and investigate their response to different signals.
9. Investigate operational amplifier circuits, which use various input and output transducers.
10. Design and construct digital circuits using logic gates to perform functions such as alarms and door locks.
11. Construct and test flip-flop circuits using logic gates to switch devices on and off in a controlled fashion.

## UNIT 2

### MODULE 2: A.C. THEORY AND ELECTRONICS (cont'd)

#### PRACTICAL ACTIVITIES

*The teacher is urged to reinforce the relevant approved codes and safety practices during the delivery of all practical activities in the Module.*

#### THE GAIN OF AN INVERTING AMPLIFIER

**Refer to Specific Objective 4.11**

**Aim:** To plot the transfer characteristic of an op. amp. connected as an inverting amplifier and measure its gain.

**Method:** Set up the circuit shown. Use one of the potential dividers provided on the op. amp. Board to control the input and digital voltmeters to monitor the input and the output p.d.'s.

Use the data collected to plot the transfer characteristic ( $V_o$  against  $V_i$ ).

Find the gain of the amplifier from a second graph of the linear region only and compare the value with the theoretical value.

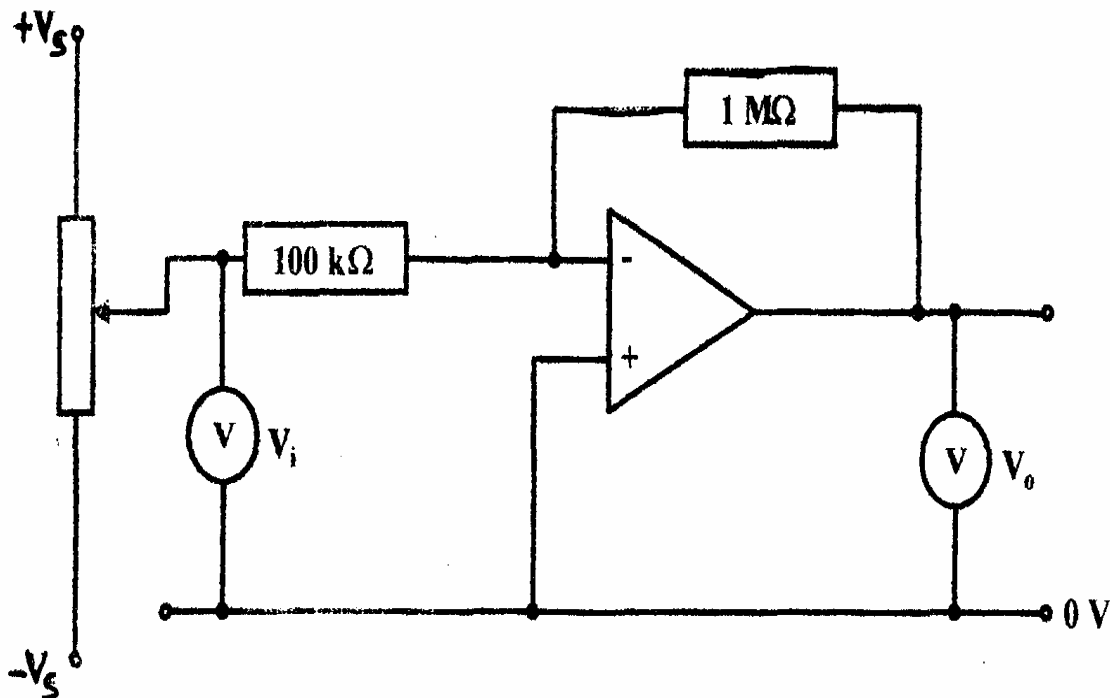



## UNIT 2

### MODULE 2: A.C. THEORY AND ELECTRONICS (cont'd)

#### **THE FREQUENCY RESPONSE OF A NON-INVERTING AMPLIFIER**

##### **Refer to Specific Objective 4.11**

**Aim:** To investigate how the gain of an amplifier changes when the frequency is increased.

**Method:** Using one of the blue op. amp. circuit boards, set up a non-inverting amplifier with a feedback resistance of  $1000\text{ k}\Omega$  and input resistance of  $10\text{ k}\Omega$ . Theoretically the gain should be 101 but, given the tolerance of the resistors, it can be taken as 100 for the purposes of this investigation.

Use an audio-frequency signal generator to provide a sinusoidal input and monitor both the input signal and the output using a double beam oscilloscope.

Note:

1. Make sure that both the gain controls of the c.r.o. are set on calibrate before taking measurements.
2. A quick way to check that the gain of the non-inverting amplifier is 100 is to set the gain (volts per division) for the output trace on a value 100 times bigger than that for the input trace. If the gain is 100 the two traces will then be the same size.
3. If the output is saturated the input signal may be reduced using the volume control and/or the attenuator control.

Repeat the investigation using a gain of about 1000 and plot log graphs to display the results of your investigation.

**UNIT 2**  
**MODULE 3: ATOMIC AND NUCLEAR PHYSICS**

**GENERAL OBJECTIVES**

On completion of this Module, students should:

1. appreciate the photon model for electromagnetic radiation;
2. understand the *development of the nuclear model of the atom*;
3. *appreciate the wave-particle nature of matter and energy*;
4. understand the relationship between mass and energy;
5. *demonstrate a knowledge of radioactivity and its applications.*

**SPECIFIC OBJECTIVES**

**EXPLANATORY NOTES**

**1. Particulate Nature of Electromagnetic Radiation**

Students should be able to:

- 1.1 use the relationship  $E = hf$  to solve problems;
- 1.2 describe the phenomenon of photoelectric emission;
- 1.3 discuss the inability of classical physics to explain aspects of the photoelectric effect;
- 1.4 use the photon model as the basis for explaining the classical paradoxes associated with photoelectric emission;
- 1.5 define 'work function' ( $\Phi$ ), 'threshold frequency' ( $f_0$ ), 'cut-off wavelength' ( $\lambda_0$ ) and 'stopping potential' ( $V_s$ );
- 1.6 use the relationship  $hf = \Phi + \frac{1}{2}mv^2$  to solve problems;

$$\Phi = hf_0$$

$$\text{Or } hf = \Phi + eV_s$$

**UNIT 2**  
**MODULE 3: ATOMIC AND NUCLEAR PHYSICS (cont'd)**

**SPECIFIC OBJECTIVES**

**EXPLANATORY NOTES**

**Particulate Nature of Electromagnetic Radiation**  
**(cont'd)**

Students should be able to:

1.7 use the electron-volt as a unit of energy;

Students should be familiar with calculations for converting the KE of particles to eV.

1.8 discuss the photoelectric effect as evidence for the particulate nature of electromagnetic radiation;

1.9 explain the process of X-ray production;

Include the fact that the emission spectrum has a continuous background component and several line spectra series.

1.10 explain the origins of line and continuous X-ray spectra;

1.11 use the relationship  $I = I_0 \exp(-\mu x)$  for the attenuation of X-rays in matter;

$\mu$  = linear absorption co-efficient.

1.12 discuss the use of X-rays in radiotherapy and imaging in medicine;

Qualitative description of the operation of a CAT scanner should be included here.

1.13 discuss how line spectra provide evidence for discrete energy levels in isolated atoms;

1.14 use the relationship  $hf = E_2 - E_1$  to solve problems;

1.15 distinguish between absorption and emission line spectra;

1.16 *explain the wave-particle nature of matter;*

## UNIT 2

### MODULE 3: ATOMIC AND NUCLEAR PHYSICS (cont'd)

#### SPECIFIC OBJECTIVES

#### EXPLANATORY NOTES

#### Particulate Nature of Electromagnetic Radiation (cont'd)

Students should be able to:

- 1.17 describe and interpret the evidence provided by electron diffraction for the wave nature of particles;
- 1.18 discuss interference and diffraction as evidence of the wave nature of electromagnetic radiation;
- 1.19 use the relation for the de Broglie wavelength  $\lambda = h/p$ .

#### **2. Atomic Structure**

Students should be able to:

- 2.1 describe the (Geiger-Marsden)  $\alpha$ -particle scattering experiment and discuss the evidence it provides for the nuclear model of the atom;
- 2.2 use the relation  $A = Z + N$  to solve problems;
- 2.3 explain the term 'isotope';
- 2.4 use the standard notation for representing a nuclide;
- 2.5 describe Millikan's oil drop experiment;
- 2.6 discuss the evidence in Millikan's oil drop experiment for the quantization of charge.

Brief account of early theories of atomic structure, including those of Thomson, Bohr and Rutherford, should introduce this section.

For example,  ${}^{14}_7\text{N}$

*Include details of Millikan's experimental design.*

*Include interpretation of graphical representation of results.*

## UNIT 2

### MODULE 3: ATOMIC AND NUCLEAR PHYSICS (cont'd)

#### SPECIFIC OBJECTIVES

#### EXPLANATORY NOTES

3.1 define 'mass defect' and 'binding energy';

3.2 calculate mass defect and binding energy;

|| 3.3 use the relationship between energy and mass in nuclear reactions  $\Delta E = \Delta m c^2$ ;

*Include calculation of energy release in fission, fusion or nuclear decay.* ||

3.4 use the atomic mass unit (u) as a unit of energy;

3.5 represent graphically the relationship between binding energy per nucleon and nucleon number;

3.6 explain the relationship between binding energy per nucleon and nuclear fission and fusion;

3.7 demonstrate that nucleon number, proton number, energy (mass) and charge are all conserved in nuclear processes;

|| 3.8 represent and interpret nuclear reactions in the form:  $11H + 21H = 32He$ .

#### 4. Radioactivity

Students should be able to:

4.1 relate radioactivity to nuclear instability;

|| 4.2 discuss the spontaneous and random nature of nuclear decay;

*See suggested practical activity on page 62.* ||

4.3 identify the origins and environmental

The deleterious effects of high energy



hazards of background radiation;

radiation on living tissue should be highlighted.

**UNIT 2**  
**MODULE 3: ATOMIC AND NUCLEAR PHYSICS (cont'd)**

**SPECIFIC OBJECTIVES**

**EXPLANATORY NOTES**

**Radioactivity (cont'd)**

Students should be able to:

4.4 describe experiments to distinguish between the three types of emissions from radioactive substances;

4.5 *write and interpret equations for radioactive decay;*

4.6 discuss the environmental hazards of radioactive emissions;

4.7 discuss the necessary safety precautions for handling and disposal of radioactive material;

4.8 explain 'activity', 'decay constant' and 'half-life', and use the relationship  $A = \lambda N$ ;

4.9 use the law of decay  $\frac{dN}{dt} = -\lambda N$  and  $N = N_0 \exp(-\lambda t)$  to solve problems;

4.10 use the relation  $T_{1/2} = \frac{\ln 2}{\lambda}$  to solve problems;

4.11 describe an experiment to determine the half-life of a radioactive isotope with a short half-life;

4.12 discuss uses of radioisotopes as tracers for carbon dating and in radiotherapy;

4.13 describe the operation of simple detectors.

Special attention should be focused on potential nuclear biohazards in the Caribbean environment.

*See suggested practical activity on page 63.*

*See suggested practical activity on page 63.*

The characteristics of an isotope which make it suitable for use in radiotherapy should be highlighted.

(For example, G-M tube, spark counter, cloud chamber).

**UNIT 2**

## MODULE 3: ATOMIC AND NUCLEAR PHYSICS (cont'd)

### **Suggested Teaching and Learning Activities**

|| *To facilitate students' attainment of the objectives of this Module, teachers are advised to engage students in teaching and learning activities listed below.* ||

1. Examine the line spectra of different substances to deduce information about energy levels.
2. Measure the absorption effect of different materials of different thickness (on the three types of radioactive emissions).
3. *Test whether the water loss from a burette is exponential.*
4. *Perform a radioactive decay simulation using dice.*



## UNIT 2

### MODULE 3: ATOMIC AND NUCLEAR PHYSICS (cont'd)

#### PRACTICAL ACTIVITIES

**The teacher is urged to reinforce the relevant approved codes and safety practices during the delivery of all practical activities in the Module.**

#### RADIOACTIVITY

##### Refer to Specific Objective 4.2

- Aims:**
- (a) To show that radioactive decay is a random process.
  - (b) To investigate the decay of thoron (radon-220) gas.

- Method:**
- (a) Radium-226 has a half-life of 1620 years and so its activity cannot change appreciably during the course of an experiment.

Set the scaler-timer on “rate” and “continuous”. Bring the radium source close to the G-M tube and leave it fixed in this position. Obtain a series of readings for the count-rate and plot them on a histogram to show their distribution about the mean value.

(b) Thoron gas is an isotope of radon  ${}_{86}^{220}\text{Rn}$  produced in the radioactive series that starts with a long half-life isotope of thorium  ${}_{90}^{232}\text{Th}$ . All the other nuclides in the series have half-lives either much longer or much shorter than thoron gas so they do not contribute to the activity of the sample of the gas. The thorium is in powdered form in a sealed plastic bottle and the thoron gas is produced in the air space above the powder.

Set the scaler timer to “count”. Find the background count-rate by switching on the counter for 100s. This value is used to correct the count-rates in the thoron decay.

Using two-tubes with one-way valves, the radon gas can be transferred into a bottle containing the end of a Geiger-Muller tube by squeezing the thorium bottle a few times. The whole system is sealed and should be quite safe but to make sure, keep all the windows open and **if any leak occurs, evacuate the room, and report to your teacher or the laboratory technician immediately.**

When the gas is transferred, switch on the counter and start timing. Record the count every 20 seconds for about 5 minutes. From these readings the number of decays in each 20s interval can be found and hence the count-rate at 10s, 30s, 50s.

Plot a graph to show how the activity varies with time and use the graph to obtain a value for the half-life of the radon.

The activity of the thoron (radon-220) will decay exponentially so you should be able to derive an equation suitable for plotting a linear graph from which the half-life may also be found. By selecting the part of the graph before the decay gets too random a more precise value than the first one may be obtained.

## UNIT 2

### MODULE 3: ATOMIC AND NUCLEAR PHYSICS (cont'd)

#### **RADIOACTIVE DECAY SIMULATION**

##### **Refer to Specific Objective 4.8**

**Aim:** To verify some of the principles of radioactivity using dice as simulated atoms.

**Method:** Throw the entire set of 500 cubes into the large tray provided and remove every cube with a six facing up. It may be necessary to carefully move some of the cubes so that they are not stacked on top each other. Place the remaining cubes into the original container and repeat the entire process until less than 10 cubes are left. Plot the total number left for each trial against the throw number. You should remember that the curve should be smooth. It does not need to go through every point.

Also, use the data to plot a linear graph. From each graph determine the half-life of your cubes in terms of throws and, from this, find the decay constant.

How does the decay constant compare with the probability of an individual cube “decaying”?

#### **HALF-LIFE OF A CAPACITOR DISCHARGE**

##### **Refer to Specific Objective 4.9**

**Aim:** To use the concept of half-life to accurately measure a large capacitance.

##### **Theory**

During discharge, the p.d. across a capacitor varies exponentially:

$$V = V_0 \exp(-t / RC)$$

Use this equation to derive the relationship between  $RC$  and the half-life of the discharge (that is, the time it takes for the p.d. to fall  $1/2 V_0$ ).

**Method:** You will be provided with a set of 1% tolerance resistors and a high impedance (digital) voltmeter. Design a suitable circuit and have the supervisor check it before switching on.

Use the circuit to find the average time it takes for the p.d. to reduce to half its initial value. Vary the value of  $R$  to obtain sufficient data to plot a suitable linear graph. Use the graph to determine the given capacitance.

## ◆ **OUTLINE OF ASSESSMENT**

### **EXTERNAL ASSESSMENT (80%)**

**Paper 01**                      *Forty-five multiple-choice items, 15 from each*                      40%  
(1 hour 30 minutes)                      *Module. Each item is worth 1 mark.*

**Paper 02**                      *Section A - Three compulsory structured*                      40%  
(2 hours 30 minutes)                      *questions, one from each Module. Each question*  
*is worth 15 marks.*

*Section B – Three compulsory essay questions one  
from each Module. Each question is worth 15  
marks.*

### **INTERNAL ASSESSMENT (20%)**

The internal assessment will consist of selected practical laboratory exercises.

### **MODERATION OF INTERNAL ASSESSMENT**

*An Internal Assessment Record Sheet will be sent each year to schools submitting students for the examination.*

*All Internal Assessment Record Sheets and sample of assignments must be submitted to reach CXC by May 31 of the year of the examination. A sample of assignments will be requested by CXC for moderation purposes.*

*These assignments will be re-assessed by CXC Examiners who moderate the Internal Assessment. Teachers' marks may be adjusted as a result of moderation. The Examiners' comments will be sent to schools.*

*Copies of the students' assignment that are not submitted must be retained by the school until three months after publication by CXC of the examination results.*

### **ASSESSMENT DETAILS**

Each Unit of the syllabus is assessed as outlined below.

#### **External Assessment by Written Papers (80% of Total Assessment)**

1. There will be a combined question paper and answer booklet for Paper 01, and for Section A of Paper 02. A separate answer booklet will be provided for Section B of Paper 02.
2. S.I. Units will be used on all examination papers.

3. The use of silent, non-programmable calculators will be allowed in the examination. Candidates are responsible for providing their own calculators.

**Paper 01 (1 hour 30 minutes – 40% of Total Assessment)**

**1. Composition of the Paper**

*This paper will consist of forty-five multiple-choice items, fifteen from each Module. All questions are compulsory and knowledge of the entire Unit is expected. The paper will assess the candidate's knowledge across the breadth of the Unit.*

*The questions will test KC and UK skills.*

**2. Mark Allocation**

*The paper will be worth 45 marks, with each question being allocated 1 mark.*

**3. Question Type**

*Questions may be presented using diagrams, data, graphs, prose or other stimulus material.*

**Paper 02 (2 hours 30 minutes - 40% of Total Assessment)**

**1. Composition of Paper**

*This paper will consist of two sections.*

*Questions on this paper test all three skills KC, UK and XS.*

*Section A will consist of three compulsory structured questions testing the application of experimental skills, one question from each Module.*

*Section B will consist of three compulsory essay questions, one from each Module. Knowledge of the entire Unit is expected.*

**2. Mark Allocation**

*The paper will be worth 90 marks.*

<i>Section A - each question</i>	-	<i>15 marks</i>
<i>Section B - each essay</i>	-	<i>15 marks</i>
<i>Total marks of Section A</i>	-	<i>45 marks</i>
<i>Total marks of Section B</i>	-	<i>45 marks</i>

**3. Question Type**

*Questions in Section A will be presented in a structured form. The questions will test KC and*



*UK skills.*

*Questions in Section B will be essays. The mark allocation for each section will be included. Answers for this section are to be written in a separate answer booklet. The questions will test KC, UK and XS skills.*

### **Internal Assessment (20%)**

Internal Assessment is an integral part of student assessment in the course covered by this syllabus. It is intended to assist students in acquiring certain knowledge, skills, and attitudes that are associated with the subject. The activities for the Internal Assessment are linked to the syllabus and should form part of the learning activities to enable the student to achieve the objectives of the syllabus.

During the course of study for the subject, students obtain marks for the competence they develop and demonstrate in undertaking their Internal Assessment assignments. These marks contribute to the final marks and grades that are awarded to students for their performance in the examination.

Internal Assessment provides an opportunity to individualise a part of the curriculum to meet the needs of students. It facilitates feedback to the student at various stages of the experience. This helps to build the self-confidence of students as they proceed with their studies. Internal Assessment also facilitates the development of the critical skills and abilities emphasised by this CAPE subject and enhances the validity of the examination on which candidate performance is reported. Internal Assessment, therefore, makes a significant and unique contribution to both the development of relevant skills and the testing and rewarding of students for the development of those skills.

The Caribbean Examinations Council seeks to ensure that the Internal Assessment scores that contribute to the overall scores of candidates are reliable estimates of accomplishment. The guidelines provided in this syllabus are intended to assist in doing so.

### **Award of Marks**

The following skills will be assessed:

- a. Analysis and Interpretation
- b. Manipulation and Measurement
- c. Observation, Recording and Reporting
- d. Planning and Designing

In each Unit, a total of 12 marks are to be allocated for each skill as indicated in the Table on page 67.

**Table**  
**Internal Assessment Skills**

Skills	Unit 1	Unit 2
*Observation, Recording and Reporting	12 marks	12 marks
Manipulation and Measurement	12 marks	12 marks
Analysis and Interpretation	12 marks	12 marks
Planning and Designing	12 marks	12 marks
<b>TOTAL</b>	<b>48 marks</b>	<b>48 marks</b>

**\*Five of the 12 marks for Observation, Recording and Reporting (ORR) are to be awarded for communicating information in a logical way using correct grammar as described in the definition of the Observation, Recording and Reporting skills on pages 3 and 4. Teachers are required to provide criteria which clearly indicate how they award marks.**

Each Module carries a maximum of 16 marks.

Each candidate's Internal Assessment mark for any Unit should be divided by three and allocated to Each Module equally.

Fractional marks should not be awarded. Wherever the Unit mark is not divisible by three, then

- (a) when the remainder mark is 1, it should be allocated to Module 1;
- (b) when the remainder is 2, one of the marks should be allocated to Module 2 and the other mark to Module 3.

Appropriate practical exercises for assessing any skill may be selected from any Module in the relevant Unit. **Teachers should aim to have candidates perform four or five practicals per module.**

### **Specific Guidelines for Teachers**

1. Each candidate is required to keep a laboratory workbook which is to be marked by the teacher. Teachers are also expected to assess candidates as they perform practical exercises in which Manipulation and Measurement skills are required.
2. A maximum of two skills may be assessed by any one experiment.
3. The maximum mark for any skill will be 12. The mark recorded for each skill assessed by practical exercises should be the average of at LEAST TWO separate assessments. In each Unit, total marks awarded at the end of each Module will be 0 to 16.
4. Specific Objectives lending themselves to practical work are highlighted by single underlining. However, teachers need not confine their practical exercises to these objectives.

## **INTERNAL ASSESSMENT – GENERAL GUIDELINES FOR TEACHERS**

1. For each Unit, marks must be submitted to CXC on the Internal Assessment forms provided. The forms should be despatched through the Local Registrar for submission to CXC by May 31 of the year of the examination.
2. The Internal Assessment Forms for each Unit should be completed in duplicate. The original should be submitted to CXC and the copy retained by the school.
3. CXC will require a sample of the laboratory books for external moderation. Additional laboratory books may be required. These laboratory books must be retained by the school for at least three months after publication of examination results.
4. Candidates who do not fulfill the requirements for the Internal Assessment will be considered absent from the whole examination.
5. Teachers are asked to note the following:
  - (i) candidates' laboratory books should contain all practical work undertaken during the course of study. Those exercises which are selected for use for Internal Assessment should be clearly identified. The skill(s) tested in these practical exercises, the marks assigned and the scale used must be placed next to the relevant exercises;
  - (ii) teachers' criteria and breakdown of marks for assessing a skill must be clearly stated and submitted with the laboratory books;
  - (iii) the relationship between the marks in the laboratory books and those submitted on the Internal Assessment Form should be clearly shown;
  - (iv) the standard of marking should be consistent.

### **◆ REGULATIONS FOR PRIVATE CANDIDATES**

1. Candidates who are registered privately will be required to sit Papers 01, 02 and 03B. Detailed information on Papers 01 and 02 is given on page 65 of this syllabus.
2. **Paper 03B (Alternate to Internal Assessment) - 20%**

This paper will be of 2½ hours duration and will consist of TWO practical questions. The examination will be designed to test the same skills (Table 1 on page 67) as the Internal Assessment.

### **◆ REGULATIONS FOR RESIT CANDIDATES**

Candidates, who have earned a moderated score of at least 50% of the total marks for the Internal Assessment component, may elect not to repeat this component, provided they re-write the



examination no later than TWO years following their first attempt. These resit candidates must complete Papers 01 and 02 of the examination for the year in which they register.

Resit candidates must be entered through a school or other approved educational institution.

Candidates who have obtained less than 50% of the marks for the Internal Assessment component must repeat the component at any subsequent sitting or write Paper 03B.

## ◆ ASSESSMENT GRID

The Assessment Grid for each Unit contains marks assigned to papers and to Modules and percentage contribution of each paper to total scores.

<b>Papers</b>	<b>Module 1</b>	<b>Module 2</b>	<b>Module 3</b>	<b>Total</b>	<b>(%)</b>
<b>External Assessment</b>					
<i>Paper 01</i> <i>(1 hour 30 minutes)</i> <i>Multiple Choice</i>	15 30 <i>(weighted)</i>	15 30 <i>(weighted)</i>	15 30 <i>(weighted)</i>	45 90 <i>(weighted)</i>	(40)
<i>Paper 02</i> <i>(2 hours 30 minutes)</i> <i>A. Structured questions</i> <i>B. Essay questions</i>	15 15	15 15	15 15	45 45	(40)
<b>Internal Assessment</b> <i>Papers 03A or 03B</i>	16	16	16	48	(20)
<b>TOTAL</b>	<b>76</b>	<b>76</b>	<b>76</b>	<b>228</b>	<b>(100)</b>



## ◆ RESOURCES

### TEXTBOOKS

#### Recommended Texts

- Adams, Steve and Allay, Jonathan      *Advanced Physics, Oxford:* Oxford University Press, 2000.
- Breithaupt, Jim      *Understanding Physics for Advanced Level, 4<sup>th</sup> Edition,* Cheltenham: Nelson Thornes Publishers, 1999.
- Muncaster, Roger      *Advanced Level Physics, 4<sup>th</sup> Edition,* London: Nelson Thornes Publishers, 1993.

#### Supplementary Texts

- Christman, Richard J.      *A Student's Companion: Halliday, Resnick and Walker. Fundamentals of Physics (including extended chapter),* New York: John Wiley and Sons, Inc., 1997.
- Duncan, Tom      *Advanced Physics,* London: Hodder Murray, 2000.
- Duncan, Tom      *Electronics for Today and Tomorrow,* London: Hodder Murray, 1997.
- Floyd, Thomas      *Digital Fundamentals, London: (Prentice Hall) Pearson,* 2005.
- Giancoli, Douglas C.      *Physics: Principles with Applications,* London: Prentice Hall, 2004.
- Halliday, David; Resnic, Robert; and Walker, Jearl      *Fundamentals of Physics, 8<sup>th</sup> Edition,* New York: John Wiley and Sons, Inc., 2007.
- Hallsworth, K.D.      *Electronic Boxes, Barbados: Akada Media.*
- Nelkon, Michael and Parker, Phillip      *Advanced Level Physics,* London: Heinemann, 1994.
- Reviere, Ruth et al.      *Preliminary Physics Study Guide,* Cave Hill, Barbados: The University of West Indies, 1997.

## ◆ GLOSSARY

### KEY TO ABBREVIATIONS

KC – Knowledge and Comprehension

UK – Use of Knowledge

XS – Experimental Skills

WORD	DEFINITION	NOTES
<b>Analyse</b>	examine in details.	(UK)
<b>Annotate</b>	requires a brief note to be added to a label.	
<b>Apply</b>	requires the use of knowledge or principles to solve problems and to explain or predict behaviours in other situations.	(UK)
<b>Assess</b>	requires the inclusion of reasons for the importance of particular structures, relationships or processes.	(UK)
<b>Calculate</b>	requires a numerical answer for which working must be shown.	(UK)
<b>Cite</b>	requires a quotation or a reference to the subject.	(KC)
<b>Classify</b>	requires a division into groups according to observable and stated characteristics.	(UK)
<b>Comment</b>	requires the statement of an opinion or a view, with supporting reasons.	(UK)
<b>Compare</b>	requires a statement about similarities and differences.	(UK)
<b>Construct</b>	requires <u>either</u> the use of a specific format for the representations, such as graphs, using data or material provided or drawn from practical investigations, <u>or</u> the building of models <u>or</u> the drawing of scale diagrams.	(UK)

<b>WORD</b>	<b>DEFINITION</b>	<b>NOTES</b>
<b>Deduce</b>	implies the making of logical connections between pieces of information.	(UK)
<b>Define</b>	requires a formal statement or an equivalent paraphrase, such as the defining equation with symbols identified.	(KC)
<b>Demonstrate</b>	show; requires an algebraic deduction to prove a given equation.	(KC/UK)
<b>Derive</b>	implies a deduction, determination, or extraction of some relationship, formula or result from data by a logical set of steps.	(UK)
<b>Describe</b>	requires a statement in words (using diagrams where appropriate) of the main points of the topic. This can also imply the inclusion of reference to (visual) observations associated with particular phenomena or experiments. The amount of description intended should be interpreted from the context.	(KC)
<b>Design</b>	includes planning and presentation with appropriate practical detail.	(UK/XS)
<b>Determine</b>	implies that the quantity concerned should not be measured directly but should be obtained by calculation or derivation.	(UK)
<b>Develop</b>	implies an expansion or elaboration of an idea or argument, with supporting evidence.	(UK)
<b>Differentiate or Distinguish</b>	requires a statement and brief explanation of the differences between or among items which can be used to define the items or place them into separate categories.	(KC/UK)
<b>Discuss</b>	requires a critical account of the points involved in the topic.	(UK)

<b>WORD</b>	<b>DEFINITION</b>	<b>NOTES</b>
<b>Draw</b>	requires a line representation of the item, showing accurate relationships between the parts.	(KC/UK)
<b>Estimate</b>	implies a reasoned order of magnitude, statement or calculation of the quantity concerned, using such simplifying assumptions as may be necessary about points of principle and about the values of quantities not otherwise included.	(UK)
<b>Evaluate</b>	requires the weighing of evidence and judgements based on stated criteria.	(UK)
<b>Explain</b>	implies that a definition or a description should be given, together with some relevant comment on the significance or context of the term or situation concerned. The amount of supplementary comment intended should be interpreted from the context.	(KC/UK)
<b>Find</b>	requires the location of a feature or the determination as from a graph.	(KC)
<b>Formulate</b>	implies the articulation of a hypothesis.	(UK)
<b>Identify</b>	requires the naming of specific components or features.	(KC)
<b>Illustrate</b>	implies a clear demonstration, using appropriate examples or diagrams.	(KC)
<b>Interpret</b>	explain the meaning of.	(UK)
<b>Investigate</b>	requires the careful and accurate gathering and analysis of data concerning a given topic (numerical or otherwise).	
<b>Label</b>	implies the inclusion of names to identify structures or parts as indicated by pointers.	(KC)

<b>WORD</b>	<b>DEFINITION</b>	<b>NOTES</b>
<b>List</b>	requires a number of points with no elaboration. Where a given number of points is specified, this should not be exceeded.	(KC)
<b>Measure</b>	implies that the quantity concerned can be directly obtained from a suitable measuring instrument.	(UK/XS)
<b>Name</b>	requires only the identification of the item.	(KC)
<b>Note</b>	implies recording observations.	(KC/XS)
<b>Observe</b>	implies the direction of attention to details which characterise reaction or change taking place and examination and scientific notations.	(UK/XS)
<b>Plan</b>	implies preparation to conduct an exercise or operation.	(XS)
<b>Predict</b>	implies the use of information to arrive at a likely conclusion or the suggestion of possible outcomes.	(UK)
<b>Record</b>	implies an accurate account or description of the full range of observations made during given procedure.	(XS)
<b>Relate</b>	implies the demonstration of connections between sets of facts or data.	(UK)
<b>Show</b>	See Demonstrate.	
<b>Sketch</b>	in relation to graphs, implies that the shape or position of the curve need only be qualitatively correct and depending on the context, some quantitative aspects may need to be included. In relation to diagrams, implies that a simple, freehand drawing is acceptable, provided proportions and important details are made clear.	(KC/UK/XS)

<b>WORD</b>	<b>DEFINITION</b>	<b>NOTES</b>
<b>State</b>	implies a concise statement with little or no supporting argument.	(KC)
<b>Suggest</b>	could imply either that there is no unique response or the need to apply general knowledge to a novel situation.	(UK)
<b>Test</b>	implies the determination of a result by following set procedures.	(UK/XS)
<b>Use</b>	implies the need to recall and apply knowledge or principles in order to solve problems and to explain or predict behaviours.	(UK)

## ◆ LIST OF MINIMUM LABORATORY REQUIREMENTS

### || *Electricity and Magnetism* ||

1. Balances (spring and top-pan).
2. Measuring equipment (stop watches, micrometers, metre rules, vernier caliper).
3. Trolleys (for momentum experiments).
4. Springs, strings, pulleys.

### **Oscillations and Waves**

1. Diffraction gratings, waves sources, turning forks, resonance tube  
ray boxes, slinkies, ripple tanks, pendulum bobs.
2. Lenses of various powers, glass blocks, prisms.

### **Thermal and Mechanical Properties of Matter**

1. Heat sources (heating coils, bunsen burners).
2. Measuring equipment: Thermometers, calorimeters..

### **Electromagnetism**

1. Good and bad conductor samples (copper rods and wire, nylon wire, constantan wire (and other resistance wires), plastic wrap or cling film, glass rods, polythene rods, strips of material (fur or cotton)).
2. Magnets, plotting compasses.
3. Hall probe.
4. *Signal generator.*
5. *C.R.O.*
6. *Capacitors (for example, 500  $\mu F$ , 2000  $\mu F$ , 4000  $\mu F$ )*

## LIST OF MINIMUM LABORATORY REQUIREMENTS (cont'd)

### || *A.C. Theory and Electronics* ||

1. Logic gates (NAND, NOR, NOT, AND and OR), breadboards, connecting wires.
2. Semiconductor diodes, operational amplifiers, capacitors, resistors, rheostats, (potential divider) thermistors.
3. Measuring equipment: Multimeters, centre-zero galvanometers, varying ranges. voltmeters and ammeters – all of
4. AC-DC power supplies, soldering irons, microphones, speakers, bulbs. 1.5V dry cells, battery holders, flashlight

### **Atomic and Nuclear Physics**

1.  $\alpha$ ,  $\beta$  and  $\gamma$  (lab) sources.
2. GM tubes.
3. Geiger counters.
4. Absorption materials: Lead (Pb), Aluminium (Al) foil.



## ◆ LIST OF PHYSICAL CONSTANTS

Universal gravitational constant	$G$	$=$	$6.67 \times 10^{-11} \text{ N m}^2 \text{ kg}^{-2}$
Acceleration due to gravity	$g$	$=$	$9.80 \text{ m s}^{-2}$
Radius of the Earth	$R_E$	$=$	$6380 \text{ km}$
Mass of the Earth	$M_E$	$=$	$5.98 \times 10^{24} \text{ kg}$
Mass of the Moon	$M_M$	$=$	$7.35 \times 10^{22} \text{ kg}$
Atmosphere	$\text{Atm}$	$=$	$1.00 \times 10^5 \text{ N m}^{-2}$
Boltzmann's constant	$k$	$=$	$1.38 \times 10^{-23} \text{ J K}^{-1}$
Coulomb constant		$=$	$9.00 \times 10^9 \text{ N m}^2 \text{ C}^{-2}$
Mass of the electron	$m_e$	$=$	$9.11 \times 10^{-31} \text{ kg}$
Electron charge	$e$	$=$	$1.60 \times 10^{-19} \text{ C}$
Density of water		$=$	$1.00 \times 10^3 \text{ kg m}^{-3}$
Resistivity of steel		$=$	$1.98 \times 10^{-7} \Omega \text{ m}$
Resistivity of copper		$=$	$1.80 \times 10^{-8} \Omega \text{ m}$
Thermal conductivity of copper		$=$	$400 \text{ W m}^{-1} \text{ K}^{-1}$
Specific heat capacity of aluminium		$=$	$910 \text{ J kg}^{-1} \text{ K}^{-1}$
Specific heat capacity of copper		$=$	$387 \text{ J kg}^{-1} \text{ K}^{-1}$
Specific heat capacity of water		$=$	$4200 \text{ J kg}^{-1} \text{ K}^{-1}$
Specific latent heat of fusion of ice		$=$	$3.34 \times 10^5 \text{ J kg}^{-1}$
Specific latent heat of vaporisation of water		$=$	$2.26 \times 10^6 \text{ J kg}^{-1}$
Avogadro number	$N_A$	$=$	$6.02 \times 10^{23} \text{ per mole}$
Speed of light in free space	$c$	$=$	$3.00 \times 10^8 \text{ m s}^{-1}$
Permeability of free space	$\mu_0$	$=$	$4\pi \times 10^{-7} \text{ H m}^{-1}$

## LIST OF PHYSICAL CONSTANTS (cont'd)

Permittivity of free space	$\epsilon_0$	=	$8.85 \times 10^{-12} \text{ F m}^{-1}$
The Planck constant	$h$	=	$6.63 \times 10^{-34} \text{ J s}$
Unified atomic mass constant	$u$	=	$1.66 \times 10^{-27} \text{ kg}$
Rest mass of proton	$m_p$	=	$1.67 \times 10^{-27} \text{ kg}$
Molar gas constant	$R$	=	$8.31 \text{ J K}^{-1} \text{ mol}^{-1}$
Stefan- Boltzmann constant	$\sigma$	=	$5.67 \times 10^{-8} \text{ W m}^{-2} \text{ K}^{-4}$
Mass of neutron	$m_n$	=	$1.67 \times 10^{-27} \text{ kg}$

## ◆ MATHEMATICAL REQUIREMENTS

### Arithmetic

Students should be able to:

1. recognise and use expressions in decimal and standard form (scientific notation);
2. recognise and use binary notations;
3. use appropriate calculating aids (electronic calculator or tables) for addition, subtraction, multiplication and division. Find arithmetic means, powers (including reciprocals and square roots), sines, cosines, tangents (and the inverse functions), natural and base-10 (In and Ig);
4. take account of accuracy in numerical work and handle calculations so that significant figures are neither lost unnecessarily nor carried beyond what is justified;
5. make approximations to check the magnitude of machine calculations.

### Algebra

Students should be able to:

1. change the subject of an equation. Most relevant equations involve only the simpler operations but may include positive and negative indices and square roots;
2. solve simple algebraic equations. Most relevant equations are linear but some may involve inverse and inverse square relationships. Linear simultaneous equations and the use of the formula to obtain the solution of quadratic equations are included;
3. substitute physical quantities into physical equations, using consistent units and check the dimensional consistency of such equations;
4. formulate simple algebraic equations as mathematical models of physical situations, and identify inadequacies of such models;
5. recognise and use the logarithmic forms of expressions like  $ab$ ,  $a/b$ ,  $x^n$ ,  $e^{kx}$ , and understand the use of logarithms in relation to quantities with values that range over several orders of magnitude;
6. express small changes or errors as percentage and *vice versa*;
7. comprehend and use the symbols  $<$ ,  $>$ ,  $\approx$ ,  $/$ ,  $\propto$ ,  $\langle x \rangle$  or  $\bar{x}$ ,  $\Sigma$ ,  $\Delta x$ ,  $\delta x$ ,  $\sqrt{\quad}$ .

## Geometry and Trigonometry

Students should be able to:

1. calculate areas of right-angled and isosceles triangles, circumferences and areas of circles and areas and volumes of rectangular blocks, cylinders and spheres;
2. use Pythagoras' theorem, similarity of triangles, and the sum of the angles of a triangle;
3. use sines, cosines and tangents (especially for  $0^\circ$ ,  $30^\circ$ ,  $45^\circ$ ,  $60^\circ$ ,  $90^\circ$ ). Use the trigonometric relationship for triangles:

$$\frac{a}{\sin A} = \frac{b}{\sin B} = \frac{c}{\sin C}; \quad a^2 = b^2 + c^2 - 2bc \cos A;$$

4. use  $\sin \theta \approx \tan \theta \approx \theta$  and  $\cos \theta \approx 1$  for small  $\theta$  and  $\sin^2 \theta + \cos^2 \theta = 1$ ;
5. understand the relationship between degrees and radians (defined as arc/radius), translate from one to the other and use the appropriate system in context.

## Vectors

Students should be able to:

1. find the resultant of two coplanar vectors, recognising situations where vector addition is appropriate;
2. obtain expressions for components of a vector in perpendicular directions *and using this to add or subtract vectors.*

## Graphs

Students should be able to:

1. translate information between graphical, numerical, algebraic and verbal forms;
2. select appropriate variables and scales for graph plotting;
3. determine the slope, intercept and intersection for linear graphs;
4. choose by inspection, a line which will serve as the best line through a set of data points presented graphically;
5. recall standard linear form  $y = mx + c$  and rearrange relationships into linear form where appropriate;

6. sketch and recognise the forms of plots of common simple expressions like  $1/x$ ,  $x^2$ ,  $a/x^2$ ,  $\sin x$ ,  $\cos x$ ,  $e^{-x}$ ,  $\sin^2 x$ ,  $\cos^2 x$ ;
7. use logarithmic plots to test exponential and power law variations;
8. understand, draw and use the slope of a tangent to a curve as a means to obtain the gradient, and use notation in the form  $dy/dx$  for a rate of change;
9. understand and use the area below a curve, where the area has physical significance.

## ◆ SUMMARY OF KEY QUANTITIES, SYMBOLS AND UNITS

The following list illustrates the symbols and units which will be used in question papers.

<i>Quantity</i>	<i>Usual Symbols</i>	<i>Usual Unit</i>
<u>Base Quantities</u>		
mass	M	kg
length	L	m
time	T	s
electric current	I	A
Luminous intensity	$I_v$	cd
thermodynamic temperature	$\theta$	K
amount of substance	N	mol
<u>Other Quantities</u>		
distance	D	m
displacement	s, x	m
area	A	$m^2$
volume	V, v	$m^3$
density	$\rho$	$kg\ m^{-3}$
speed	u, v, w, c	$m\ s^{-1}$
velocity	u, v, w, c	$m\ s^{-1}$
acceleration	a	$m\ s^{-2}$
acceleration of free fall	g	$m\ s^{-2}$
force	F	N

## SUMMARY OF KEY QUANTITIES, SYMBOLS AND UNITS (cont'd)

<i>Quantity</i>	<i>Usual Symbols</i>	<i>Usual Unit</i>
<u>Other Quantities (cont'd)</u>		
weight	W	N
momentum	p	N s
work	w, W	J
energy	E, U, W	J
potential energy	$E_p$	J
kinetic energy	$E_k$	J
heat energy	Q	J
change of internal energy	$\Delta U$	J
power	P	W
pressure	p	Pa
torque	$\tau$	N m
gravitational constant	G	$\text{N kg}^{-2} \text{m}^2$
gravitational field strength	g	$\text{N kg}^{-1}$
gravitational potential	$\phi$	$\text{J kg}^{-1}$
angle	$\theta$	$^\circ$ , rad
angular displacement	$\theta$	$^\circ$ , rad
angular speed	$\omega$	$\text{rad s}^{-1}$
angular velocity	$\omega$	$\text{rad s}^{-1}$
period	T	s
frequency	f	Hz

## SUMMARY OF KEY QUANTITIES, SYMBOLS AND UNITS (cont'd)

<i>Quantity</i>	<i>Usual Symbols</i>	<i>Usual Unit</i>
<i>Other Quantities (cont'd)</i>		
angular frequency	$\omega$	rad s <sup>-1</sup>
wavelength	$\lambda$	m
speed of electromagnetic waves	c	m s <sup>-1</sup>
electric charge	Q	C
elementary charge	e	C
electric potential	V	V
electric potential difference	V	V
electromotive force	E	V
resistance	R	$\Omega$
resistivity	$\rho$	$\Omega$ m
electric field strength	E	N C <sup>-1</sup> , V m <sup>-1</sup>
permittivity of free space	$\epsilon_0$	F m <sup>-1</sup>
capacitance	C	F
time constant	$\tau$	s
magnetic flux	$\Phi$	Wb
magnetic flux density	B	T
permeability of free space	$\mu_0$	H m <sup>-1</sup>
stress	$\sigma$	Pa
strain	$\epsilon$	
force constant	k	N m <sup>-1</sup>

## SUMMARY OF KEY QUANTITIES, SYMBOLS AND UNITS (cont'd)



<b>Quantity</b>	<b>Usual Symbols</b>	<b>Usual Unit</b>
<u>Other Quantities (cont'd)</u>		
Young modulus	E	Pa
Celsius temperature	$\theta$	$^{\circ}\text{C}$
molar gas constant	R	$\text{J K}^{-1} \text{mol}^{-1}$
Boltzmann constant	k	$\text{J K}^{-1}$
Avogadro constant	$N_{\text{A}}$	$\text{mol}^{-1}$
number density (number per unit volume)	N	$\text{m}^{-3}$
Planck constant	h	J s
work function energy	$\Phi$	J
activity of radioactive source	A	Bq
decay constant	$\lambda$	$\text{s}^{-1}$
half-life	$t_{1/2}$	s
relative atomic mass	$A_{\text{r}}$	
relative molecular mass	$M_{\text{r}}$	
atomic mass	$m_{\text{a}}$	kg, u
electron mass	$m_{\text{e}}$	kg, u
neutron mass	$m_{\text{n}}$	kg, u
proton mass	$m_{\text{p}}$	kg, u
molar mass	M	kg
proton number	Z	
nucleon number	A	
neutron number	N	
Stefan-Boltzmann constant	$\sigma$	$\text{W m}^{-2} \text{K}^{-4}$

**Western Zone Office**  
**2007/06/26**